

**Report
On
“Expert talk: Involvement of
Youth in Cybercrime in
India”**

Held on 08th July 2017

Organised by
Internal Quality Assurance Cell, RITE, Odisha



Principal
Radhakrishna Institute of Technology
and Engineering, Bhubaneswar

Notice:

Radhakrishna Institute of Technology &
Engineering, Bhubaneswar
(BPUT affiliated, AICTE approved & NAAC accredited)



Ref. No: RITE/2017-18/11-A

Date: 08-07/2017

NOTICE

Sub: - "Involvement of Youth in Cybercrime In India"

The Radhakrishna Institute of Technology is going to organize an expert talk on "Involvement of Youth in Cybercrime in India" as per the following details. All students and staff are required to attend the program without fail.

Resource Person: Mr. Nityananda Pradhan, Advocate, Khordha

Date: 08th July 2017

Time: 11:00 AM to 12:00 Noon

Venue: Seminar Hall



DIRECTOR (I/c)

Copy to: Asst. Director/ All HODs/ NBS



Principal
Radhakrishna Institute of Technology
and Engineering, Bhubaneswar

RITE Bhubaneswar, IDCO Plot-1, IDCO Industrial Estate, Barunei, Bhubaneswar-752057, India
Te/fax: 01-6755-220242, Email: riteodisha@gmail.com Web: www.riteindia.in



Principal
Radhakrishna Institute of Technology
and Engineering, Bhubaneswar

Background:

Cybercrime is criminal activity that either targets or uses a computer, a computer network or a networked device. Most cybercrime is committed by cybercriminals or hackers who want to make money. However, occasionally cybercrime aims to damage computers or networks for reasons other than profit.

From last few years, it has been observed that there has been 53.5% rise in the Cyber Crime. According to a report many cyber criminals were arrested, who were mostly the young adults. Out of 324 people arrested under the IT Act, 215 were from the age group of 18–30 years.

Brochure of the event:

RADHAKRISHNA INSTITUTE OF TECHNOLOGY AND ENGINEERING



Expert talk on

INVOLVEMENT OF YOUTH IN CYBERCRIME IN INDIA

Resource Person

Mr. Nityananda Pradhan

Advocate, Khordha

Contact : 8984152449

Email : n.pradhankhd@gmail.com

Date :

08/07/2017

Time :

11:00 AM - 12:00 PM

Venue :

Seminar Hall

Objective

To aware the audience regarding “**Involvement of Youth in Cybercrime in India**”.

Schedule of the Event

Time	Event
11.00am-11.10am	Inaugural ceremony
11.10 am-11.20am	Introductory speech by Dr. M. Sarkar, Dept of Management Studies, RITE
11.2am- 12.20pm	Talk delivered on “Involvement of Youth in Cybercrime in India” by the expert.
12.20 pm-12.30pm	Vote of thanks & felicitation by honorable Principal, RITE.

Participants

- Students of RITE
- DDU-GKY (RITE)
- All the teaching and non-teaching staffs of RITE
- People situated nearby RITE, BBSR

About the Expert: Mr. Nityananda Pradhan, Advocate, Khordha



Principal
Radhakrishna Institute of Technology
and Engineering, Bhubaneswar

Mr. Nityananda Pradhan

Advocate, Khordha

Enrollment No : 0-240/1990



From,

Mr. Nityananda Pradhan

Advocate, Khordha

Dear Principal,

Radhakrishna Institute of Technology and Engineering

IDCO Plot No-1, Khordha Industrial Estate, Bhubaneswar

I am writing to express my sincerest appreciation to you and your team for inviting me to speak about **"Involvement of Youth in Cybercrime in India"** to your students on **08.07.2017**. It was an honour and privilege to be given the opportunity to share my experience and knowledge with the students of your esteemed college.

The experience of speaking to your students was truly rewarding for me. The level of engagement and interaction from the students was outstanding, and I greatly enjoyed the insightful questions and comments that were raised during the session. The enthusiasm and interest displayed by the students are a testament to the quality of education provided by your college.

I commend your college for its commitment to providing a well-rounded education to its students. The opportunity to speak at your college allowed me to contribute to this mission and promote education, particularly in the field of law. I'm sure the students have benefitted greatly from the discussion, and I hope that the information I shared motivated them to achieve their goals.

Once again, thank you for giving me this opportunity to speak to your students. It was a memorable experience for me, and I'm glad I could contribute to your stellar program. I look forward to collaborating with you and the college in the future.

Sincerely,

Nityananda Pradhan



[Signature]
Principal
Radhakrishna Institute of Technology
and Engineering, Bhubaneswar

Contact : +91 8984152449, Email : n.pradhankhd@gmail.com

Department of Electrical Engineering

Report On

“Emerging Electrical System”



Expert Talk On
“ EMERGING ELECTRICAL SYSTEM ”

Organized By
Department of
ELECTRICAL ENGINEERING

Keynote Speaker
Mr. Prasanta Kumar Pattnaik
DGM(E & MR Division), OPTCL, Bhubaneswar

Date : 22nd August 2017
Venue : RITE Seminar Hall

 RITE RADHAKRISHNA INSTITUTE OF TECHNOLOGY AND ENGINEERING

EXPERT: Mr. Prasant Kumar Pattanaik
DGM (E&MR DIVISION)
OPTCL, BHUBANESWAR



Principal
Radhakrishna Institute of Technology
and Engineering, Bhubaneswar

Date and Time: 22nd AUGUST-2017, 02.00pm

Venue: RITE seminar hall

Duration: 3 hours

Faculty Co-ordinators:

Prof. Subash Ranjan Kabat (Head, EE Department)

Prof. Deepak Kumar Sahoo (Asst Professor, EE Department)

Prof. Barsha Parija (Asst Professor, EE Department)

Prof. Chinmayee Mishra (Asst Professor, EE Department)

Prof. Surya Narayan Tripathy (Asst Professor, EE Department)

Total Number of Students: 57

Expert Profile:

Mr. Prasant Kumar Pattanaik

Email ID: ele.pkpattanaik@optcl.co.in

Address: Vani Vihar

Bhubaneswar

Work Profile: He has 26years of industry experience in various level of EHT systems. He looks after protection control, counseling to system development. His specialization includes development of techno commercial design of protection control schemes. He has published 80 technical papers in National and International Arena and regular technical writer to electrical mirror, Electrical India, IEEMA Journal and others. He has been awarded with best paper worth 1 lakh metering India 2017 Conference

Website: <http://optcl.co.in>



Principal
Radhakrishna Institute of Technology
and Engineering, Bhubaneswar

Training Team

The members of the training team of “**Emerging Power System**” organized by the faculty members of Electrical Engineering department, RITE, Bhubaneswar.

AGENDA

<u>TIME</u>	<u>EVENTS</u>
2.00PM	Inauguration
2.05 PM	Welcoming the Guests to the dais
2.10 PM	Welcome speech by Barsha Parija
2.15 PM	Welcome Address by Director I/C
2.30PM	Talk By P K Pattanaik,DGM,OPTCL
4.45 PM	Vote of Thanks by HOD,EE

About Expert Talk:

Students gathered around 1:30 pm on August 22nd, Tuesday for Expert Lecture. Talk initiated at 02:15am with an auspicious prayer. Dignitaries were welcomed to the dias.

A Welcome speech was given by Prof. Barsha Parija followed by introduction for the Hod & Director. A brief speech motivating students to pursue careers in innovative tech industry was given by Dr. S.S kanungo (Director, RITE). The Director also introduces the expert to the gatherings. After that the Expert Mr. P.K.Pattanaik started his talk about “**Emerging Power System**”.

Technical Summary:

Mr. Pattanaik presented the history of Power system by explaining terms like transmission, distribution & utilization. Students were explained the difference between power voltage & current relationship for the transmission of electrical power from source to destination. The Fault in transmission line was explained Reality through videos and animation.

The complete power scenario has been explained .The different reason for fault in the transmission line with examples has been explained.

TRANSMISSION SCENERIO OF THE COUNTRY

Transmission Grid 1947 to 2007
Installed Capacity 1349 MW to 1,40,000 MW
Transmission System Local Grid to Regional Grid

1960s - State Grid
1970s - Regional Grid
1990s - Interconnecting Regional Grid
Asynchronously with Limited
Interregional Capacity
2000 onwards - Towards National Grid



Principal
Radhakrishna Institute of Technology
and Engineering, Bhubaneswar

Transmission System

- Transmission Systems are Highways for transport of Electrical Energy
- The key to power system operation lies in effective and efficient transfer capability in the transmission system.
- Transmission owners may fragment the electricity market
- To this end transmission open access was taken up

Challenges:

- ❖ To have adequate network in the State & Country
- ❖ Large quantum of power transformation. over long distance
- ❖ Rajiv Gandhi Grameen Vidyutikaran Yojana (RGGVY) and Biju Grameen Jyoti Yojana (BGJY)
- ❖ Planned and phase wise replacement of old Transmission elements
- ❖ Reduction of Transmission Loss

Technologies for Transmission

- ❖ Enhancing the capacity of existing system
- ❖ State-of-the-Art maintenance techniques being practiced
- ❖ High Temp endurance conductor for increased Loading
- ❖ Multi-conductor Bundle line
- ❖ Tall & Multi circuit Towers to avoid deforestation and protection of wild life.
- ❖ Compact Tower / Pole Tower to reduce Right Of Way

Advance concepts:

- ❖ LADR (Load Accessed Directional Relay)
- ❖ Super grid (Hybrid transmission system supported 1200kV, 765kV, 400kV UHVAC & ± 800 kV, ± 500 kV HVDC system).
- ❖ Intelligent Power system protection & control
 - WAMS (Wide Area Monitoring Systems)
 - FACTS devices, and controller interaction
 - OPGW (Optical Fiber Ground Wire)
 - Congestion Management and control
 - SMART Grid Technology



Principal
Radhakrishna Institute of Technology
and Engineering, Bhubaneswar

Future Technologies - Intelligent Grid

- Need for infusion of Intelligence in the Grid for :
 - Knowing the state of the Grid
 - Predict the catastrophic situation in advance
 - Take corrective actions accordingly so as to protect the grid
- Features of Intelligent Grid
 - adoptive islanding,
 - self-healing
 - demand/generation management etc.
- To accomplish, need for Wide Area Monitoring System (WAMS).
 - To gather and processing the data from any number of GPS-synchronized phasor measurement units (PMUs) along with a system monitoring centre and take corrective action through advance software and control system

After explaining the technical concept the expert concludes with a beautiful line that is

***If we don't strive for change,
then change may drive us away."***

Participants

All the faculty members of RadhaKrishna Institute of Technology and Engineering .Also the lovely technocrats with their uniform participate in the Expert Talk.

Outcomes of the Expert Talk

- ❖ Learn about the technology behind the transmission system.
- ❖ Learn about the new technology of the protection system.
- ❖ Learn about the reason behind the blackout condition of power system.
- ❖ Learn about the technical modification of transmission and protection system.



Principal
Radhakrishna Institute of Technology
and Engineering, Bhubaneswar

PHOTOGRAPHS:





Principal
Raddhakrishna Institute of Technology
and Engineering, Bhubaneswar



VALEDICTORY SESSION:

The expert talk was over at 4.45 pm. Then vote of thanks has been given by the Head of the department, Electrical engineering. After that the Director felicitated the expert. The expert talk on emerging power system was completed at 5 pm.



REPORT PREPARED BY:

Prof Subash Ranjan Kabat
HOD, EE

Prof Deepak Kumar Sahoo
Asst Professor, EE

Principal
Radhakrishna Institute of Technology
and Engineering, Bhubaneswar

Radhakrishna Institute of Technology &
Engineering, Bhubaneswar

(BPUT affiliated, AICTE approved & NAAC accredited)



Workshop Report
On

“Recent Trends in Java Technology:
SPRING Framework”

Held on: 4th September 2017

Organized by:

**Department of Computer Science and Engineering in
Association with IQAC RITE, BHUBANESWAR.**

Principal
Radhakrishna Institute of Technology
and Engineering, Bhubaneswar

Index:

- Background
- Notice
- Brochure of the Event
- Schedule of the Event
- Brief Profile of the Speaker
- List of Participation
- Pictures of the Event



Principal
Radhakrishna Institute of Technology
and Engineering, Bhubaneswar

Background:

Spring is one of the most popular open source framework for developing enterprise applications. It provides comprehensive infrastructure support for developing Java based applications.

Spring also enables the developer to create high performing, reusable, easily testable and loose coupling enterprise Java application.

Key Strategies of spring:

1. Spring is a light weight framework and it minimally invasive development with POJO.
2. Spring achieves the loose coupling through dependency injection and interface based programming.
3. Spring supports declarative programming through aspects and common conventions.
4. Boilerplate reduction through aspects and templates.

Advantages:

Spring enables the developers to develop enterprise applications using POJOs (Plain Old Java Object). The benefit of developing the applications using POJO is, that we do not need to have an enterprise container such as an application server but we have the option of using a robust servlet container.

Spring provides an abstraction layer on existing technologies like servlets, jsps, jdbc, jndi, rmi, jms and Java mail etc., to simplify the development process.

Spring comes with some of the existing technologies like ORM framework, logging framework, J2EE and JDK Timers etc, Hence we don't need to integrate explicitly those technologies.

Spring WEB framework has a well-designed web MVC framework, which provides a great alternate to legacy web framework.

Spring can eliminate the creation of the singleton and factory classes.

Spring provides a consistent transaction management interface that can scale down to a local transaction and scale up to global transactions (using JTA).

Venue: Computer Programming Lab-1, Ground Floor

Target audience: B. Tech Students, All Faculty Members

Faculty Coordinator:

Prof. Maheswar Mishra, HoD (CSE) Department, Assistant Professor



Principal
Radhakrishna Institute of Technology
and Engineering, Bhubaneswar

Brochure of the Event:

**RADHAKRISHNA INSTITUTE OF
TECHNOLOGY AND ENGINEERING**



**WORKSHOP ON
RECENT TRENDS IN JAVA TECHNOLOGY**

**SPRING FRAMEWORK BY :
SILAN TECHNOLOGY**

HELD ON : 04/09/2017

Resource Person :

Mr. Trilochan Tarai
CEO, Silan Technology



Principal
Radhakrishna Institute of Technology
and Engineering, Bhubaneswar

Notice:

Radhakrishna Institute of Technology &
Engineering, Bhubaneswar
(BPUT affiliated, AICTE approved & NAAC accredited)



REF. NO. RITE/Admin/2017-18/93 DATE: 04.09.2017

NOTICE

Sub: Workshop on "Recent Trends in Java Technology: SPRING Framework"

Radhakrishna Institute of Technology and Engineering in association IQAC is going to organize a workshop on "**Recent Trends in Java Technology: SPRING Framework**" by Silan Technology as per the following details. The students and staff are advised to attend the workshop for their betterment.

Date: 4th September 2017
Time: 2:00 PM onwards
Venue: Seminar Hall

ASST.DIRECTOR

Copy to: Director/Dean(Academics)/ All HODs/ NBs

Principal
Radhakrishna Institute of
and Engineering, Bhub

RITE Bhubaneswar, IDCO Plot-1, IDCO Industrial Estate, Barunei, Bhubaneswar-752057, India
Tefax: 91-6755-220242, Email: riteodisha@gmail.com Web: www.riteindia.in

Principal
Radhakrishna Institute of Technology
and Engineering, Bhubaneswar

Schedule of the Event:

Time	Event
1.30 PM	Inauguration
1:45 PM	Welcoming the guest to the dais
2:00 PM	Hands on Session by Guest Speaker
3:30 PM	Vote of Thanks by Prof. Maheswar Mishra

Resource Person

Mr. Trilochan Tarai , Expert in Java and Python Programing has 10+ Years' experience in industry in the field of Software Development and Training. He is ex TCS Technical Lead and also worked in the colleges as Assistant Professor.



Principal
Radhakrishna Institute of Technology
and Engineering, Bhubaneswar

List of Participation

Sl No	Name	Branch
1	Manas Ranjan Sethy	CE
2	Soumya Ranjan Sethy	CE
3	Sonadhar Madkami	CE
4	Bijay Kumar Nayak	CE
5	Abinash Routary	CSE
6	Sarojini Singh	CSE
7	Zafrul Khan	CSE
8	Sonali Ojha	CSE
9	M Alkeya Rani	CSE
10	Bipul Sardar	CSE
11	Subrat Kumar Sahoo	CSE
12	Bapinath Soren	CSE
13	Kanupriya Pati	CSE
14	Kanchan Khara	CSE
15	Tapas Chandra Behera	CSE
16	Pinaki Sethy	CSE
17	Subhashree Sahoo	CSE
18	Ashish Ranjan Rout	CSE
19	Sambit Pattnaik	EE
20	Himanshu Sekhar Chandra	EE
21	Rajesh Kumar Behera	EE
22	Sanjay Kumar Sahoo	EE
23	Swaraj Kumar Rout	ME
24	Subha Ranjan Sahoo	ME
25	Niranjan Baidya	ME
26	Amit Lenka	ME
27	Suryakant Manji	ME
28	Akhaya Amerseth	CE
29	Amit Kumar Aman	CE
30	Sohel Ansari	ME
31	Balabhadra Gadaba	CE
32	Chandra Guntha	CE
33	Renuka Ganda	CE
34	Amit Kumar Manjhee	CSE
35	Ansuman Das	CSE
36	Deepak Pandey	CSE
37	Jatin Raj Bhoi	CSE
38	Sovit Naik	CSE



Principal
Radhakrishna Institute of Technology
and Engineering, Bhubaneswar

Radhakrishna Institute of Technology & Engineering, Bhubaneswar

(BPUT affiliated, AICTE approved & NAAC accredited)



39	Debendra Bharatia	CSE
40	Soni Parida	CSE
41	Utkal Kesharee Jena	ME
42	Raj Kumar Pradhan	ME
43	Sourav Prakash Kanungo	ME
44	Bikash Kumar Pradhan	ME
45	Manas Behera	ME
46	Bibhuti Bhusan Pradhan	ME
47	Bikram Kesari Jena	ME
48	Asif Anwar	ME
49	Pravat Ranjan Nath	CSE
50	Sanghamitra Swain	CSE
51	Priyabrat Sahu	CSE
52	Sushma Giri	CSE
53	Suraj Kumar Choudhury	CSE
54	Aliva Das	CSE
55	Ashmita Khillo	CSE
56	Piyush Sinha	CSE
57	Rojalin Behera	CSE
58	Sagar Senapati	CSE
59	Rimple Benia	CSE
60	Snehil Kumar	CSE
61	Satyajit Mohapatra	CSE
62	Seshadev Prusthy	CSE
63	Debashish Mohanty	EE
64	Rupesh Mahanta	EE
65	Sunil Kumar Dalai	EE
66	Jyoti Ranjan Sahoo	EE
67	Chirasmitta Sahoo	CSE
68	Punyabati Panda	CSE
69	Bani Shree Malik	CSE
70	Santanu Kumar Mali	CE
71	Sweta Mahapatra	CE
72	Rabi Baroi	CE
73	Vivek Pradhan	CSE
74	Tarini Ranjan Sahoo	CSE
75	Ramray Marandi	CSE
76	Jatin Raj Bhoi	CSE
77	Yashabonta Patra	CE

Principal
Radhakrishna Institute of Technology
and Engineering, Bhubaneswar

Pictures of the Event

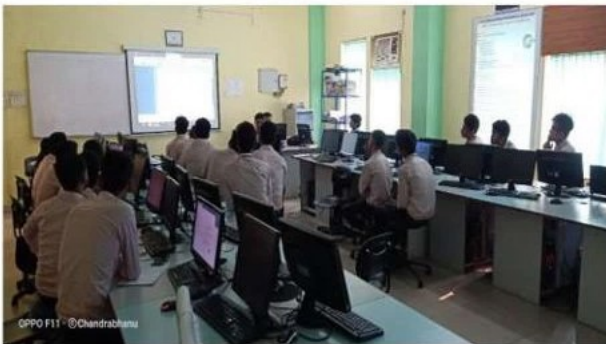

Principal
Radhakrishna Institute of Technology
and Engineering, Bhubaneswar

REPORT
ON
“OVERVIEW OF POWER GENERATION AND CHALLENGES”

Invited Talk On
“ OVERVIEW OF POWER GENERATION AND CHALLENGES ”

Organized By
Department of
MECHANICAL ENGINEERING

Keynote Speaker
Er. Debendra Nath Satapathy
Ex-AGM, Rourkela Steel Plant, SAIL, Rourkela

Date : **7th September 2017**
Venue : **RITE Seminar Hall**

 **RITE RADHAKRISHNA INSTITUTE OF TECHNOLOGY AND ENGINEERING**

Organized By
Department of Mechanical Engineering

Keynote speaker
Er. Debendranath Satapathy
Ex-AGM ,Rourkela Steel Plant ,SAIL,Rourkela



RADHAKRISHNA INSTITUTE OF TECHNOLOGY AND ENGINEERING, BHUBANESWAR- 752057 (ODISHA)

Principal
Radhakrishna Institute of Technology
and Engineering, Bhubaneswar

Date and Time: 07-SEPT -2017, 02.00pm

Venue: RITE seminar hall

Duration: 3 hours

Faculty Co-ordinators:

Prof. Chandrabhanu Malla (HOD, Department of Mechanical Engineering)

Prof. Mamuni Arya (Asst Professor, Department of Mechanical Engineering)

Prof. Bimal Ranjan Pattnaik (Asst Professor, Department of Mechanical Engineering)

Prof. Sushant Kumar Pradhan (Asst Professor, Department of Mechanical Engineering)

Prof. Surya Narayan Behera (Asst Professor, Department of Mechanical Engineering)

Prof. Prafulla Chandra Sahoo (Asst Professor, Department of Mechanical Engineering)

Prof. Amit Jain Biswal (Asst Professor, Department of Mechanical Engineering)

Total Number of Students: 80

Expert Profile:

Er. Debendranath Satapathy

Address: Rasulgarh

Bhubaneswar

Work Profile:

Er. Debendranath Satapathy former AGM, SAIL, Rourkela steel plant has completed both his Bachelor and Master degree in mechanical engineering (Heat power as specialization) from Regional engineering college Rourkela(presently NIT, Rourkela).

After completion of bachelor degree he work in Durgapur steel plant for six years and then he move two Rourkela steel plant(SAIL) and work there 19 years and completed his tenure has

He is having the specialization in the operation and maintenance of coal handling plant, ash handling plant, DM plant, Water system, boiler and turbine.

Subsequently after that Mr. Satapathy has worked at different industries in our country and abroad for 11 more years. He is having the vast experience of 37 years.

Principal
Radhakrishna Institute of Technology
and Engineering, Bhubaneswar

Training Team

The members of the training team of “**OVERVIEW OF POWER GENERATION AND CHALLENGES**” organized by the faculty members of Mechanical Engineering department, RITE, Bhubaneswar.

AGENDA

<u>TIME</u>	<u>EVENTS</u>
2.00PM	Inauguration
2.05 PM	Welcoming the Guests to the dais
2.10 PM	Welcome speech by Prof. C. Malla, HOD,ME
2.15 PM	Felicitation by Dean (Academics)
2.30PM	Presentation By Er. Debendranath Satapathy
4.30 PM	Vote of Thanks by prof A J Biswal

About the Expert Talk:

Students gathered around 1:30 pm at the Seminar Hall on 7th September 2017, for Expert Talk. The talk initiated at 02:15pm with presentation of Flower Bouquet to the speaker. Dignitaries were welcomed to the dais.

A Welcome speech was given by Prof. Chandrabhanu Malla, HOD, Mechanical Engineering. After that the invited speaker, Er. **Debendranath Satapathy** started his presentation about “**OVERVIEW OF POWER GENERATION AND CHALLENGES**”.

Principal
Radhakrishna Institute of Technology
and Engineering, Bhubaneswar

OVERVIEW OF POWER GENERATION..

The complete power scenario has been explained. The **power sector** in India is mainly governed by the Ministry of Power. There are three major pillars of power sector these are Generation, Transmission, and Distribution. As far as generation is concerned it is mainly divided into three sectors these are Central Sector, State Sector, and Private Sector. **Central Sector or Public Sector Undertakings (PSUs)**, constitute **29.78% (62826.63MW)** of total installed capacity i.e, **210951.72 MW (as on 31/12/2012)** in India. Major PSUs involved in the generation of electricity include *NHPC Ltd.*, *NTPC Ltd.*, and *Nuclear Power Corporation of India (NPCIL)*.

Besides PSUs, several **state-level corporations** are there which accounts for about **41.10%** of overall generation , such as Jharkhand State Electricity Board (JSEB), Maharashtra State Electricity Board (MSEB), Kerala State Electricity Board (KSEB), in Gujarat (MGVCL, PGVCL, DGVCL, UGVCL four distribution Companies and one controlling body GUVNL, and one generation company GSEC), are also involved in the generation and intra-state distribution of electricity.

Other than PSUs and state level corporations, **private sector enterprises** also play a major role in generation, transmission and distribution, about **29.11%(61409.24MW)** of total installed capacity is generated by private sector.

The **Power Grid Corporation** of India is responsible for the inter-state transmission of electricity and the development of national grid.

The **Ministry of Power** is the apex body responsible for the development of electrical energy in India. This ministry started functioning independently from **2 July 1992**; earlier, it was known as the Ministry of Energy. The Union Minister of Power at present is Sushilkumar Shinde and Minister of State for Power is K.C Venugopal.

India is world's **6th largest** energy consumer, accounting for **3.4%** of global energy consumption, with Maharashtra as the leading electricity generator among Indian states. Due to India's economic rise, the demand for energy has grown at an average of 3.6% per annum over the past 30 years. At the end of December 2012, the installed power generation capacity of India stood at **210951.72MW**, while the **per capita energy consumption** stood at **733.54 KWh(2008-09)**. The Indian government has set an ambitious target to add

approximately 78,000 MW of installed generation capacity by 2012. The **total demand** for electricity in India is expected to cross **950,000 MW by 2030**.

India is the **sixth largest in terms of power generation**. About **65%** of the electricity consumed in India is generated by thermal power plants, **22%** by hydroelectric power plants, **3%** by nuclear power plants and rest by **10%** from other alternate sources like solar, wind, biomass etc. **53.7%** of India's commercial energy demand is met through the country's vast coal reserves. The country has also invested heavily in recent years on renewable sources of energy such as wind energy. As of **March 2011**, India's installed wind power generation capacity stood at about **12000 MW**. Additionally, India has committed massive amount of funds for the construction of various nuclear reactors which would generate at least 30,000 MW. In July 2009, India unveiled a **\$19 billion plan to produce 20,000 MW of solar power by 2020 under National Solar Mission**.

The per capita power consumption in **India** is **733.54KWh/yr**, which is very minimal as compared to **global average** of **2340KWh/yr**.

Electricity **losses** in India during **transmission and distribution** are extremely high, about **28.44%(2008-09)**. India needs to tide over a **peak power shortfall of 13% between 5pm and 11pm** by reducing losses due to theft and pilferage.. Due to shortage of electricity, power cuts are common throughout India and this has adversely effected the country's economic growth. Theft of electricity, common in most parts of urban India, amounts to 1.5% of India's GDP. *The condition of utilities are not good either, cumulative loss of 110 power utilities are estimated as Rs 86,136 crore which is expected to rise to Rs 1,16,089 crore by 2014-15.* Despite an ambitious rural electrification program, some 400 million Indians lose electricity access during blackouts. While 84.9% of Indian villages have at least an electricity line, just **46 percent of rural households have access to electricity**.



Principal
Radhakrishna Institute of Technology
and Engineering, Bhubaneswar

ENERGY

Energy is the capacity to do work. A plenty of energy is needed to sustain industrial growth and agricultural production.

CLASSIFICATION OF ENERGY

It is broadly classified into

1. **Conventional energy:** is in practice for long duration of time and well established technology is available to tap and use them. e.g. Coal, oil, natural gas, hydro power, nuclear power etc.
2. **Non-conventional energy:** source can be used with advantage for power generation as well as other applications in a large number of locations and situations. These energy sources cannot be easily stored and used conveniently. e.g. Solar, wind, tidal and geothermal etc.

Based upon nature, energy sources are classified as

1. **Renewable energy** sources are inexhaustible and are renewed by nature itself. Solar, wind, tidal, hydro and biomass are few examples.
2. **Non-renewable energy** sources are exhaustible within a definite period of time depending upon its usage. Fossil fuels (coal, oil, gas) and nuclear fuels are few examples.

SOLAR ENERGY

The surface of the earth receives about 10^{14} kW from sun in the form of solar energy which is approximately five orders of magnitude greater than that currently being consumed from all resources. It is evident that sun will last for 10^{11} years.

There are two obvious obstacles to harnessing solar energy. Firstly it is not constantly available on earth. Thus some form of storage is needed to sustain solar energy through the night and during rainy season. Secondly the solar energy is diffused. Although the total amount of energy is enormous, the collection and conservation of solar energy into useful forms must be carried out over a large area which entails large capital investments.

SOLAR WATER HEATING

By using solar radiation, water or any fluid can be heated by using a solar collector. Such systems can provide hot water for different applications in industries directly or as boiler feed and also in hostels, hotels and canteens.

There are two types of solar collectors in use:

Principal
Radhakrishna Institute of Technology
and Engineering, Bhubaneswar

1. Flat plate collector
2. parabolic or concentrating collector

Flat plate collector:

The absorber plate is metallic. It is usually coated black to absorb more heat energy. Tubes, passages or channels integral with the collector carry water or other working fluid. Insulation should be provided at the back and at the sides to minimize the heat losses. Usually glass wool is used as insulation material. A transparent cover (glass) will be provided at the top to permit the radiation from the sun to the metal plate.

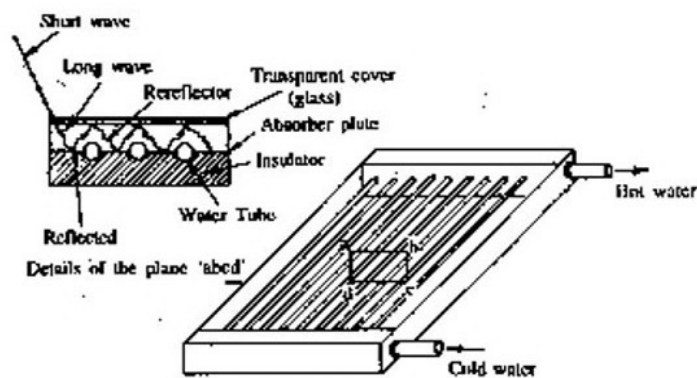

Solar flat plate collector

Flat Plate Collector

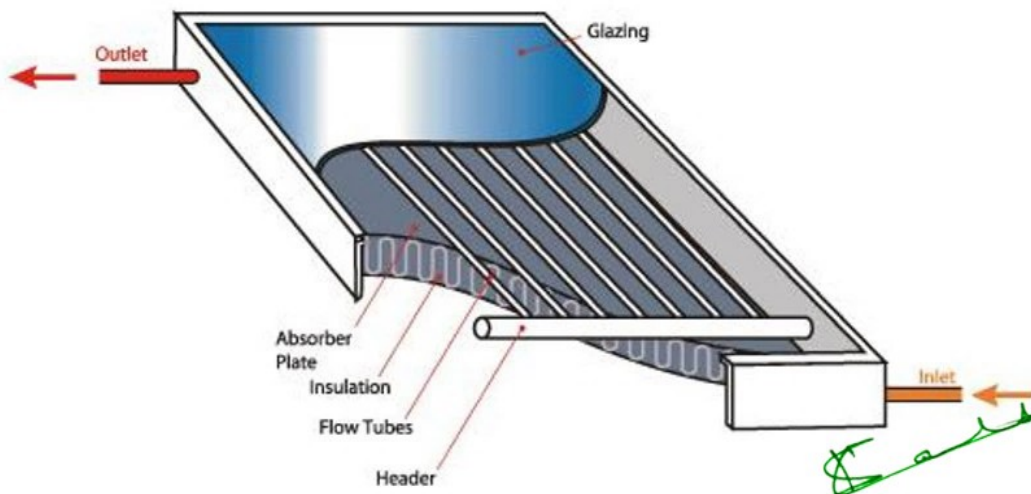

Principal
Radhakrishna Institute of Technology
and Engineering, Bhubaneswar

Parabolic or concentrating collector

Highly polished metallic surfaces are used as the reflector. The reflector will have a parabolic shape so that the sun rays striking the profile will be reflected on its focal point. If a tube carrying a fluid is kept along the focal line, the fluid will be heated to a very high temperature.

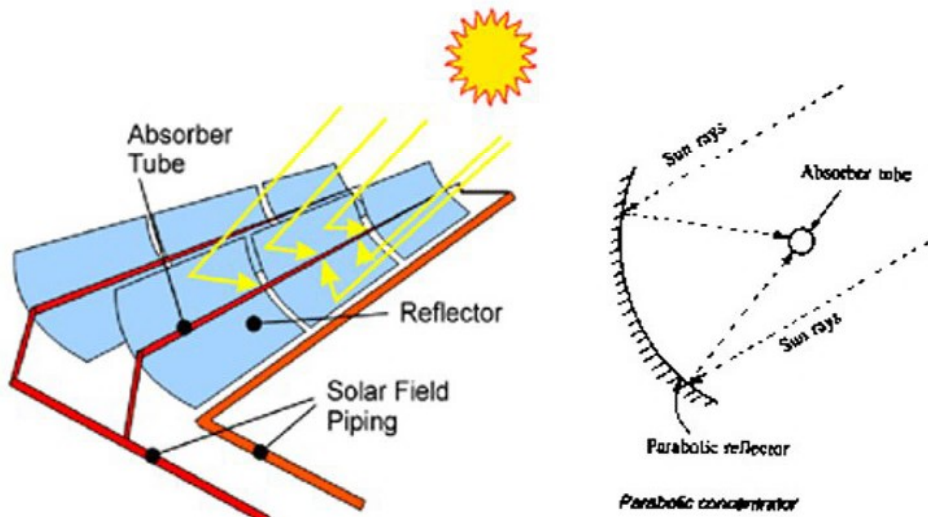

SOLAR THERMAL CONVERSION

1. Low temperature system
2. High temperature system

Low temperature system

This system uses a flat plate collector, which can heat water up to about 80°C only. Water is circulated through the flat plate collector. Heat exchanger is used to vaporize a low boiling fluid (butane) and the butane vapor will run the turbine, butane vapor is condensed and reused.

Principal
Radhakrishna Institute of Technology
and Engineering, Bhubaneswar

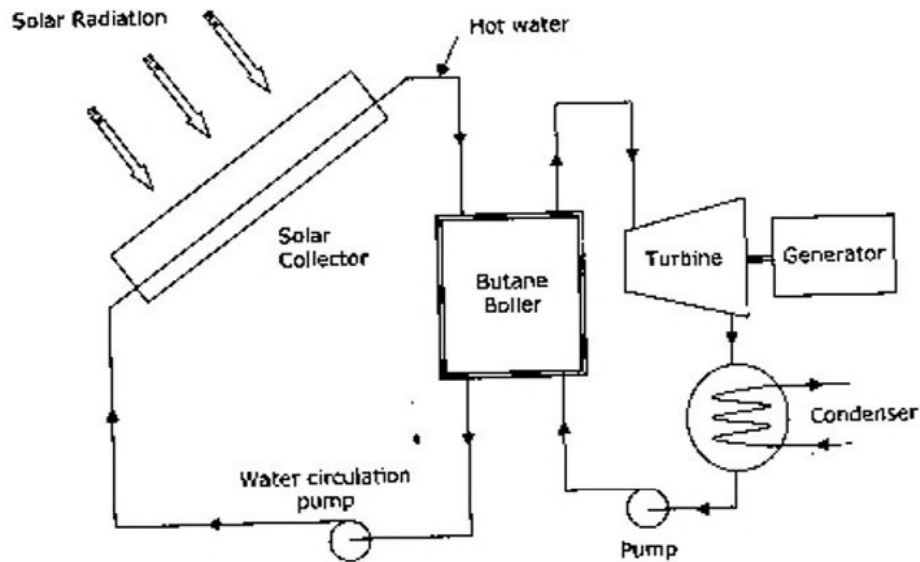

High temperature system

Solar power tower is employed for high temperature system. A receiver is mounted on the tower which is 100 to 500m high and designed to withstand the weight of the receiver. Here reflecting mirrors are known as heliostat. The heliostats are arranged in such a way that they direct the solar energy on the receiver throughout the day. This is achieved by a microprocessor based tracking system, which turns the heliostats depending on the position of sun. The receiver is designed and positioned in such a way to intercept, absorb and transfer maximum heat to working fluid. The temperature achieved is 1500°C to 1700°C. Steam generated in the receiver runs the turbine, condensed to water and recycled.

(Handwritten signature in green ink)

Principal
 Radhakrishna Institute of Technology
 and Engineering, Bhubaneswar

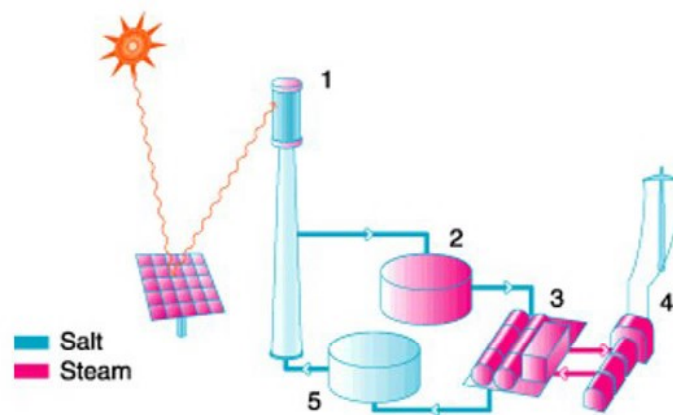
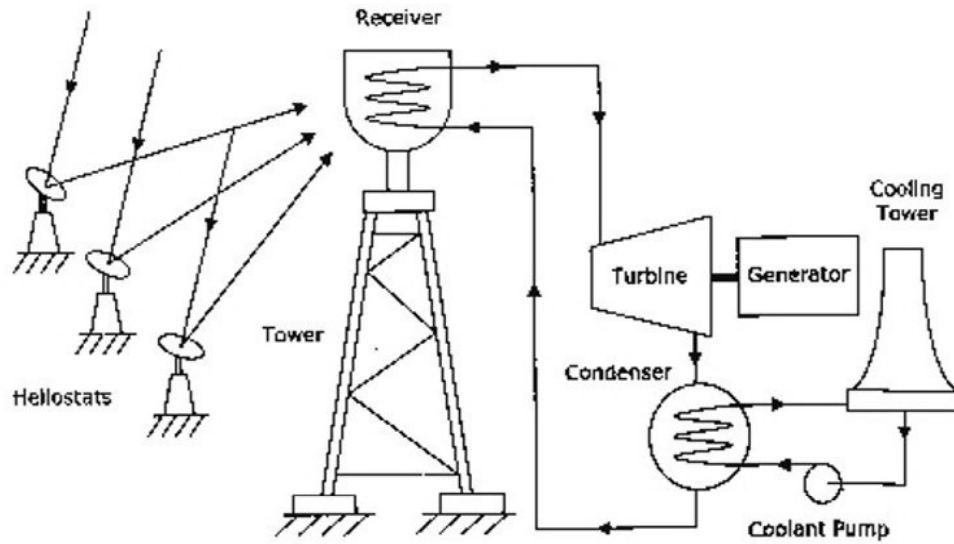

ADVANTAGES

1. Renewable source of energy
2. Pollution free
3. After the capital cost, the cost of power generation is quite low
4. Wide range of applications, powering street lights to satellites

[Handwritten signature]

DISADVANTAGES

Principal
 Radhakrishna Institute of Technology
 and Engineering, Bhubaneswar

1. Capital cost is very high
2. Large area of land is required
3. Large number of solar panels are required
4. Affected by seasons.

WIND ENERGY

The electrical energy can be generated by wind energy by utilizing the kinetic energy of wind. The wind energy which is an indirect source of energy can be used to run a wind mill which in turn drives a generator to produce electricity.

WIND MILL:

Wind mills are classified into two types

1. Horizontal axis wind turbine
2. Vertical axis wind turbine

HORIZONTAL AXIS WIND TURBINE

Horizontal axis wind turbines have the main rotor shaft running horizontally.

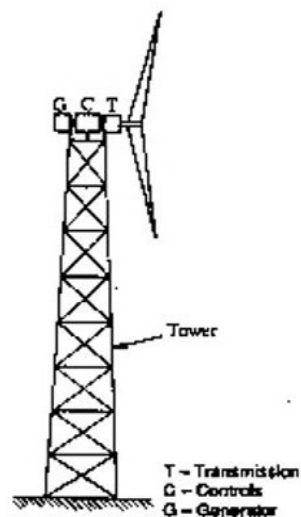

Principal
Radhakrishna Institute of Technology
and Engineering, Bhubaneswar

Fig shows a schematic arrangement of a horizontal axis machine. This system consists of a tower mounted two bladed or multi bladed rotor facing the wind, rotating around a horizontal axis and turning an electrical generator.

The Blades are generally made of composite material, usually fibre reinforced plastic (FRP) because of its high strength and light weight. Wind mills are manufactured with a capacity from a few kilowatts to several megawatts in Europe, the USA, and other parts of the world including India.

VERTICAL AXIS WIND TURBINE

Vertical axis wind turbines have the main rotor shaft running vertically. The tower construction is simple here because the generator and gear box can be placed at the bottom, near the ground.

Vertical axis wind turbine can be classified into two types

1. Darrieus type
2. Savonius type

Darrieus type rotor

This wind mill needs much less surface area. It is shaped like an egg beater and has two or three blades shaped like aero foils.

Savonius type rotor

Savonius turbine is S-shaped if viewed from top. This turbine turns relatively slow, but yields high torque. It is used for grinding grains and for pumping water.



Principal
Radhakrishna Institute of Technology
and Engineering, Bhubaneswar

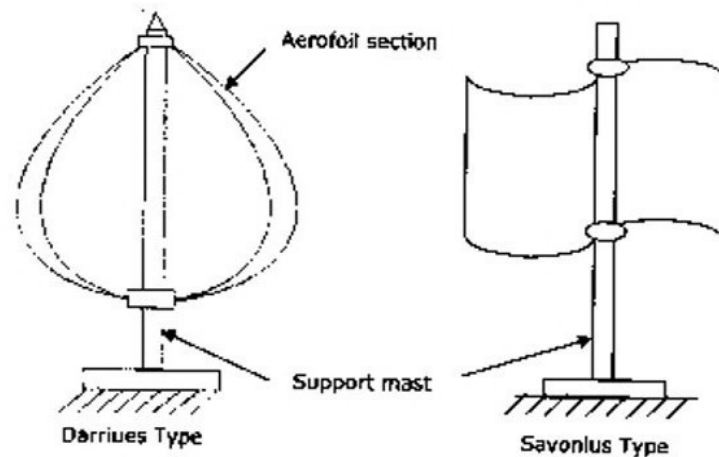

ADVANTAGES

1. Wind is Renewable and free of cost
2. Pollution free
3. Can be installed in remote villages, thus reducing costly transmission lines

DISADVANTAGES

1. Capital cost is very high
2. Large area of land is required
3. Maintenance cost is very high

TIDAL ENERGY

The periodic rise and fall of water level of sea which are carried by the action of the sun and moon on water of the earth is called “tide”. The large scale up and down movement of sea water represents an unlimited source of energy.

The main feature of the tidal cycle is the difference in water surface elevations at the high tide and at the low tide. If the differential head could be utilized in operating a hydraulic turbine, the tidal energy could be converted into electrical energy by means of an attached generator.

TIDAL POWER PLANT

A Tidal power plant mainly consists of the following:

(Handwritten signature in green ink)

Principal
Radhakrishna Institute of Technology
 and Engineering, Bhubaneswar

1. A barrage with gates and sluices
2. One or more basins
3. A power house

A barrage is a barrier constructed across the sea to create a basin for storing water. The barrage has to withstand the pressure exerted by the water head and also should resist the shock of the waves.

A basin is the area where water is retained by the barrage. Low head reversible water turbine are installed in the barrage separating the sea from the basin.-

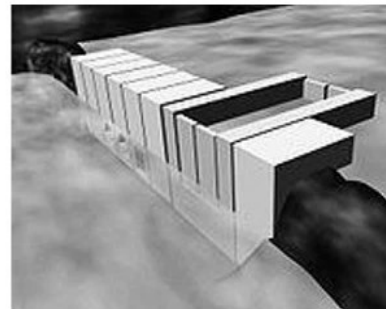
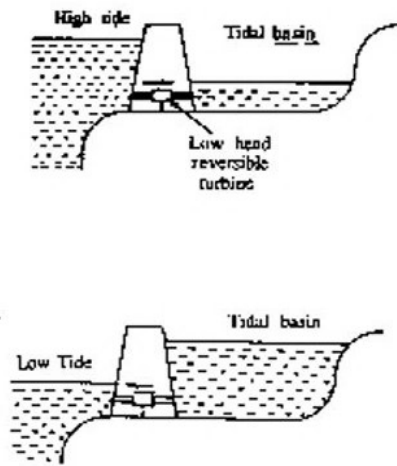

Principal
Radhakrishna Institute of Technology
and Engineering, Bhubaneswar

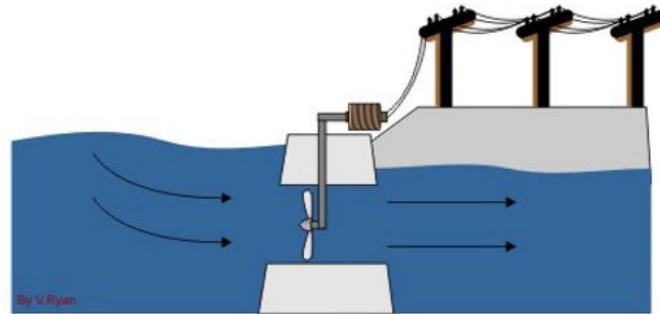

TIDE COMING IN

This tidal electricity generation works as the tide comes in and again when it goes out. The turbines are driven by the power of the sea in both directions.

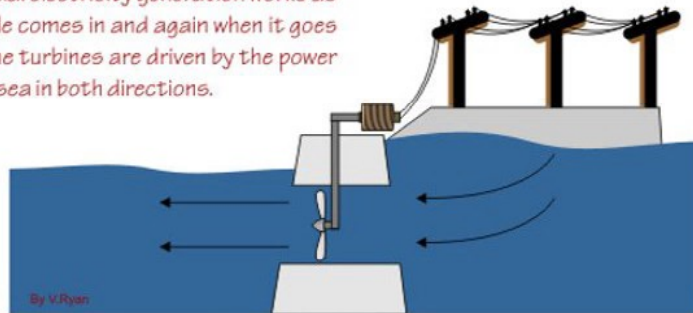

TIDE GOING OUT

During high tide, water will flow from sea to tidal basin through turbine, thus producing electricity. During low tide, water will flow from tidal basin to sea through turbine producing electricity.

ADVANTAGES

1. It is inexhaustible source of energy
2. No problem of pollution
3. The cost of power generation is quite low
4. High output can be obtained compared to solar or wind energy

DISADVANTAGES

1. Capital cost is very high
2. As the head is not constant, variable output is obtained
3. As the head is low, large amount of water is necessary for the turbine
4. It will not operate when the available head is less than 0.5m

Principal
 Radhakrishna Institute of Technology
 and Engineering, Bhubaneswar

GEOHERMAL ENERGY

Geothermal power plants derive energy from the heat of the earth's interior. The average increase in temperature with depth of the earth is 1°C for every 30-40m. At a depth of 10-15km, the earth's interior is as hot as $1000-1200^{\circ}\text{C}$. In certain areas of our planet, the underground heat has raised the temperature of water to over 200°C which bursts out as hot steam through the cracks in the earth's crust. These are called thermal springs. This steam can be utilized for power production.

GEOHERMAL SOURCES

The following five general categories of geothermal sources have been identified:

1. Hydrothermal convective systems
 - (i) Vapor dominated or dry steam fields
 - (ii) Liquid dominated or wet steam fields
 - (iii) Hot water fields
2. Geo-pressure resources
3. Petrothermal or hot dry rocks
4. Magma resources
5. Volcanoes

The hydro thermal convective systems are best resources for geothermal energy exploitation at present. Hot dry rock is also being considered.

GEOHERMAL POWER PLANTS

Geothermal wells are drilled at suitable locations. Water vaporized into steam comes out of the earth's surface in a dry condition at around 200°C and 8 bar. The moisture is removed by a centrifugal separator and this steam will run the turbine coupled with a generator. Steam is condensed in a condenser and re injected back into the ground by a rejection well.

Principal
Radhakrishna Institute of Technology
and Engineering, Bhubaneswar

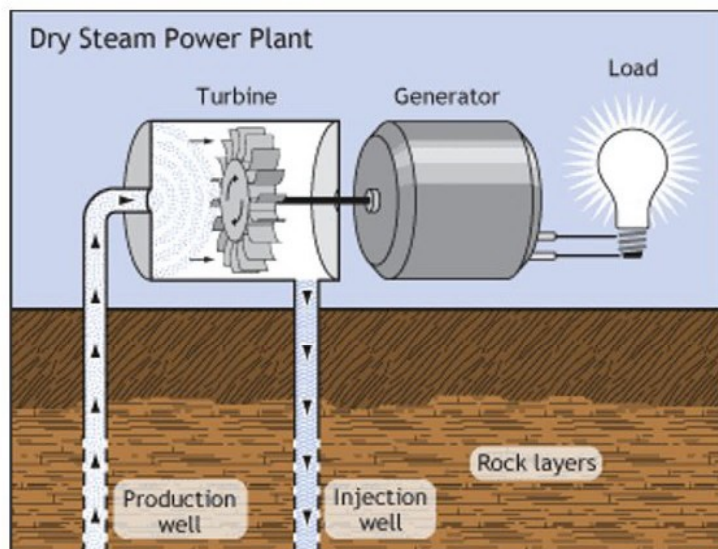
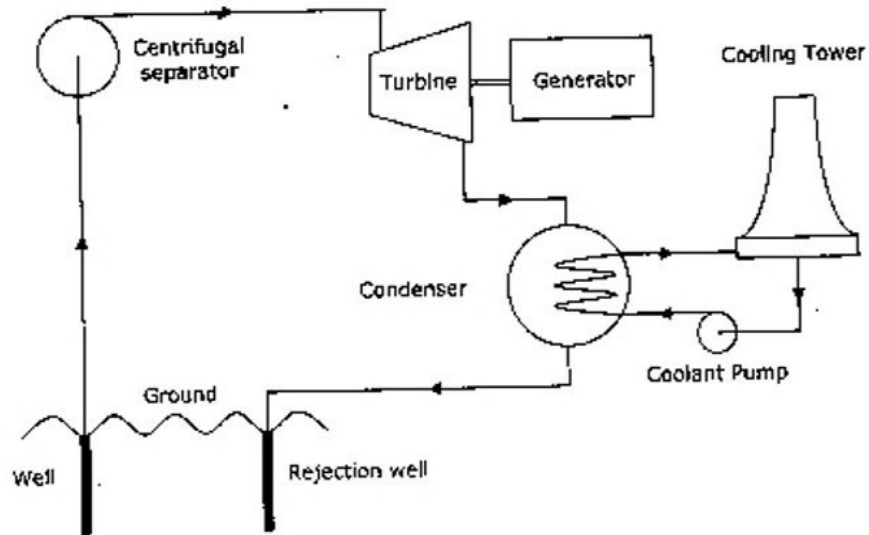

ADVANTAGES

1. Geothermal energy is cheaper
2. Used as space heating for buildings
3. Used as industrial process heat
4. Geothermal energy is inexhaustible

[Handwritten signature]

Principal
 Radhakrishna Institute of Technology
 and Engineering, Bhubaneswar

DISADVANTAGES

1. Low overall power production efficiency (about 15%)
2. Large areas are needed for exploitation of geothermal energy

OCEAN THERMAL ENERGY CONVERSION

OTEC uses the temperature difference of the sea water at different depths to generate electricity

OTEC utilizes the temperature difference that exists between the surface waters heated by the sun and the colder deep (up to 1000m) waters to run a heat engine. This source and sink provides a temperature difference of 20°C in ocean areas within 20° of the equator. These conditions exist in tropical coastal areas, roughly between the tropic of Capricorn and the tropic of cancer. Such a small temperature difference makes energy extraction difficult and expensive. Hence, typically OTEC systems have an overall efficiency of only 1 to 3%. The OTEC is shown in fig.

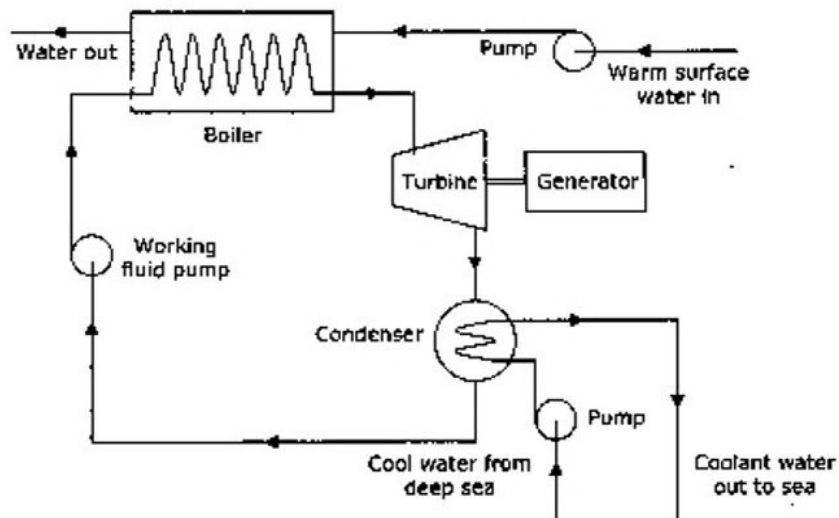

[Handwritten signature]

Principal
Radhakrishna Institute of Technology
and Engineering, Bhubaneswar

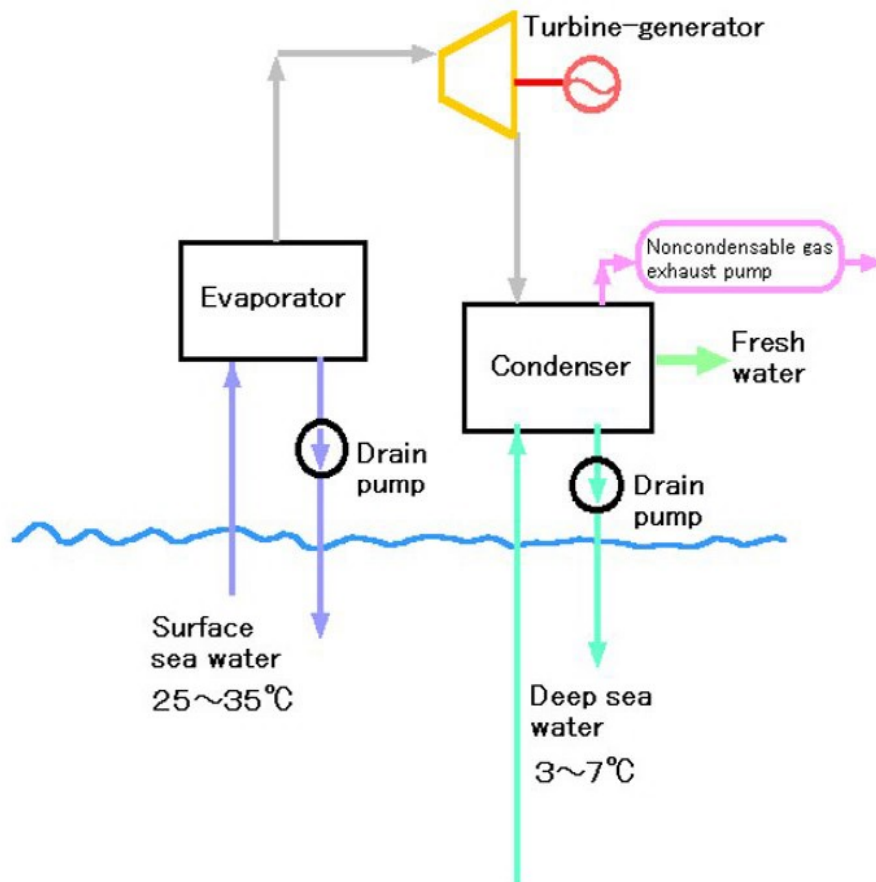

Fig.2 Conceptual figure of barometric OC-OTEC system

Challenges in the power generation..

Over-dependence on imported coal

As much as 59% of the generated power in India comes from coal-based thermal power plants. Although India has the 3rd largest coal reserves in the world, most of the domestic requirements are met through imports due to

- (a) poor quality of coal found in India (low Gross Calorific Value)
- (b) mining inefficiencies (a sluggish Coal India Ltd)
- (c) environmental issues in opening up of new mines

As such, the cost of generation of power is heavily contingent upon the ~~import~~ price of coal.

Principal
Radhakrishna Institute of Technology
and Engineering, Bhubaneswar

Transmission inefficiencies

As much as 25% of the generated power is lost in transmission in India as compared to a maximum of 5% in other Asian countries like China and South Korea. This is mainly due to lack of state-of-the-art infrastructure.

Distribution inefficiencies

Power companies can sell power only to government agencies which may either themselves distribute it to the end users or outsource the same to private players. The State Electricity Boards (SEBs) often suffer heavily due to populist measures of the government, such as giving free/cheap electricity to farmers before elections, and also due to non-payment of dues by government departments. Most SEBs are neck-deep in losses. This in turn curbs their own capacity to purchase power from the generating units. It leads to a paradoxical situation where despite their state generating surplus power, some cities/towns suffer from long periods of power-cuts every week.

Unabated power theft

Power theft is rampant in the country. Local authorities are often hand-in-glove with the power thieves. This causes huge revenue loss to the exchequer.

The way out..

- Opening up the coal mining sector to the private players to bring about efficiency
- Increasing the share of renewable energy in India's energy basket
- Improving infrastructure
- Opening up the distribution sector to the private players to induce competition and bringing an end to all populist measures
- Stringent laws against power theft and a greater emphasis on the implementation of those laws



Principal
Radhakrishna Institute of Technology
and Engineering, Bhubaneswar

PHOTOGRAPHS



(Handwritten signature)

Principal
Radhakrishna Institute of Technology
and Engineering, Bhubaneswar



[Handwritten signature in green ink]

Principal
Radhakrishna Institute of Technology
and Engineering, Bhubaneswar

Report

On

“One Day Workshop on Android: A Cutting Edge Technology”

Held on: 8th September 2017

Organized by:

**Department of Computer Science and Engineering in
Association with IQAC RITE, BHUBANESWAR.**



Principal

Index:

- Background
- Notice
- Brochure of the Event
- Schedule of the Event
- Brief Profile of the Speaker
- List of Participation
- Pictures of the Event



Principal
Radhakrishna Institute of Technology
and Engineering, Bhubaneswar

Background:

The era of globalization is characterized by the development of science very rapidly, particularly in the advancement of increasingly sophisticated technology. Advances in technology can be seen from the development of increasingly sophisticated mobile phone from generation to generation. One type of mobile phone that is widely used by most people this globalization era is kind of android. With a variety of features offered by this type of smarth phone, allowing people to access the information needed. A new breakthrough in the world of education is the use smarth phone type of android as a medium of innovative learning for learning a subject, as well as allowing students to access learning material anywhere and anytime without being limited by a classroom. The development of media on android smartphone can be used as a new breakthrough in classroom teaching and learning process interesting and fun. The use of Android-based learning media is one application of the learning styles of the 21th century. But a lot of the impact of the use of android-based instructional media in teaching and learning in class. One is addicted students to the smart phone itself. The purpose of writing this article is to examine the use of Android as a learning medium that supports the learning style of the 21st century, and to investigate the impact of the use of type android phone smart in the learning Process.

Faculty Coordinator:

Prof. Maheswar Mishra, Assistant Professor, CSE Department

Target Audience: All B.Tech Students and Faculty Members

Venue: Seminar Hall and Computer Lab



Principal
Radhakrishna Institute of Technology
and Engineering, Bhubaneswar

Brochure of the Event:

**RADHAKRISHNA INSTITUTE OF
TECHNOLOGY AND ENGINEERING**



Workshop on

android

a cutting edge technology

By : Interface Software

Date : 08/09/2017



Principal
Radhakrishna Institute of Technology
and Engineering, Bhubaneswar

Notice:

Radhakrishna Institute of Technology &
Engineering, Bhubaneswar
(BPUT affiliated, AICTE approved & NAAC accredited)

REF. NO. RITE/2017-18/199(A) DATE: 07:09:2017

NOTICE

Sub: - Workshop on "Android: A Cutting Edge Technology"

It is hereby inform to all 2nd, 3rd and 4th year students that the Department of Computer Science & Engineering is organizing a Workshop on "Android: A Cutting Edge Technology" in association with Interface Software, Bhubaneswar as per the following details. The students and faculty members are advised to attend the above said Seminar without fail.

Date: 8th September 2017
Time: 9:30 onwards
Venue: Session 1: Seminar Hall
Session 2: Computer Lab

[Signature]
07.09.2017
DIRECTOR IIC

Copy to: All Deans/ All Hods/ NBs

[Signature]
Principal
Radhakrishna Institute of Technology
and Engineering, Bhubaneswar

RITE Bhubaneswar, IDCO Plot-1, IDCO Industrial Estate, Barunei, Bhubaneswar-752057, India
Tefax: 91-6755-220242, Email: riteodisha@gmail.com Web: www.riteindia.in

Schedule of the Event:

Time	Event
9:30 AM	Inauguration
9:40 AM	Welcoming the guest to the dais
10:10 AM	Hands on Session by Guest Speaker from Interface
4:30 PM	Vote of Thanks by Prof. Maheswar Mishra

Resource Person

Mr. Jgganath Sahoo,
Software Development Trainer, Interface Software Bhubaneswar



Principal
Radhakrishna Institute of Technology
and Engineering, Bhubaneswar

List of Participation

Sl. No.	Registration No.	Name of the Students	Full Signature of the Students
1	1601367012	AMIT KUMAR MAJHEE	Amit kumar majhee
2	1601367013	ANSHUMAN DAS	
3	1601367015	BISWAJIT DEHURY	Biswajit Dehury
4	1601367016	DEEPAK PANDEY	Deepak Pandey
5	1601367017	JATIN RAJ BHOI	
6	1601367018	KRUSHNA PRASAD DAS	
7	1601367020	PREETY KUMARI	Preety Kumari
8	1601367021	RAMRAY MARNDI	Ramray Marndi
9	1601367022	SAGARIKA MISHRA	Sagarika Mishra
10	1601367023	SANGRAM KUMAR PATTANAİK	
11	1601367025	SATYANARAYAN SAHOO	
12	1601367026	SHUSHREE SARITA PAIKARAY	Shushree Sarita Paikaray
13	1601367028	SNEHASIS BISWAL	
14	1601367029	SOVIT NAIK	Sovit Naik
15	1601367030	TANMAYA PRIYADARSHINI	
16	1601367031	TARANI RANJAN SAHOO	
17	1601367032	VIVEK PRADHAN	
18	1601367033	RAJAT MOHANTY	Rajat Mohanty
19	1601367034	SMRUTIRANJAN BEURIA	
20	1601367035	SONI PARIDA	
21	1601367064	DEBENDRA BHARATIA	Debendra Bharatia
22	1601367065	DEBENDRA JENA	Debendra Jena
23	1601367066	HARAPRIYA KAR	Harapriya Kar
24	1601367068	MANASI NAYAK	Manasi Nayak
25	1601367069	RUTUPARNA PANDA	Rutuparna Panda
26	1601367070	SUBHASIS SAHOO	
27	1601367071	SUBHENDU SEKHAR BEHERA	Subhendu Sekhar Behera
28	1601367072	USHA RANI KHOSLA	
29	1601367083	SUBAL MOHALIK	

Principal
Radhakrishna Institute of Technology
and Engineering, Bhubaneswar

Radhakrishna Institute of Technology & Engineering, Bhubaneswar

(BPUT affiliated, AICTE approved & NAAC accredited)



Sl. No.	Registration No.	Name of the Students	Full Signature of the Students
1	1701367002	ABINASH ROUTRAY	Abinash Routray
2	1701367003	SAROJINI SINGH	Sarojini Singh
3	1701367007	ZAFRUL KHAN	
4	1701367008	SONALI OJHA	Sonali Ojha
5	1701367012	M ALEKYA RANI	M. Alekya Rani
6	1701367013	BIPUL SARDAR	Bipul Sardar
7	1701367014	SUBRAT KUMAR SAHOO	
8	1701367017	SMRUTI SWARUP PADHI	Smruti Swarup Padhi
9	1701367019	SIBASHANKAR MUDULI	Sibashankar muduli
10	1701367022	EAPINATH SOREN	Eapinath Soren
11	1701367023	KANUPRIYA PATI	Kanupriya Pati
12	1701367025	KANCHAN KHARA	Kanchan Khara
13	1701367028	SONALI PRIYADARSHINEE	Sonali priyadarshinee
14	1701367030	DEEPAK KUMAR BINDHANI	Deepak Kumar Bindhani
15	1701367032	SUBHASHREE SAHOO	Subhashree Sahoo
16	1701367033	SOUMYA RANJAN SAMAL	Soumya Ranjan Samal
17	1701367034	ASHISH RANJAN ROUT	
18	1701367035	SANMIT JENA	Sanmit Jena
19	1701367038	MITRABHANU SAHOO	Mitrabhanu Sahoo
20	1701367044	AJIT KHATUA	
21	1701367051	DEBIDUTTA BEHERA	Debidutta Behera
22	1701367053	JAYANTI TUDU	Jayanti Tudu
23	1701367059	P.NAVYA	P. Navya
24	1701367061	PINAKY SETHY	Pinaky sethy
25	1701367064	RAKESH OJHA	
26	1701367065	RAMA CHANDRA TUDU	Rama Chandra Tudu
27	1701367067	SHRUTISHREE NAYAK	Shrutishree nayak
28	1701367071	SUMIT KUMAR NAYAK	
29	1701367076	TAPAS CHANDRA BEHERA	

Principal
Radhakrishna Institute of Technology
and Engineering, Bhubaneswar

Pictures of the Event

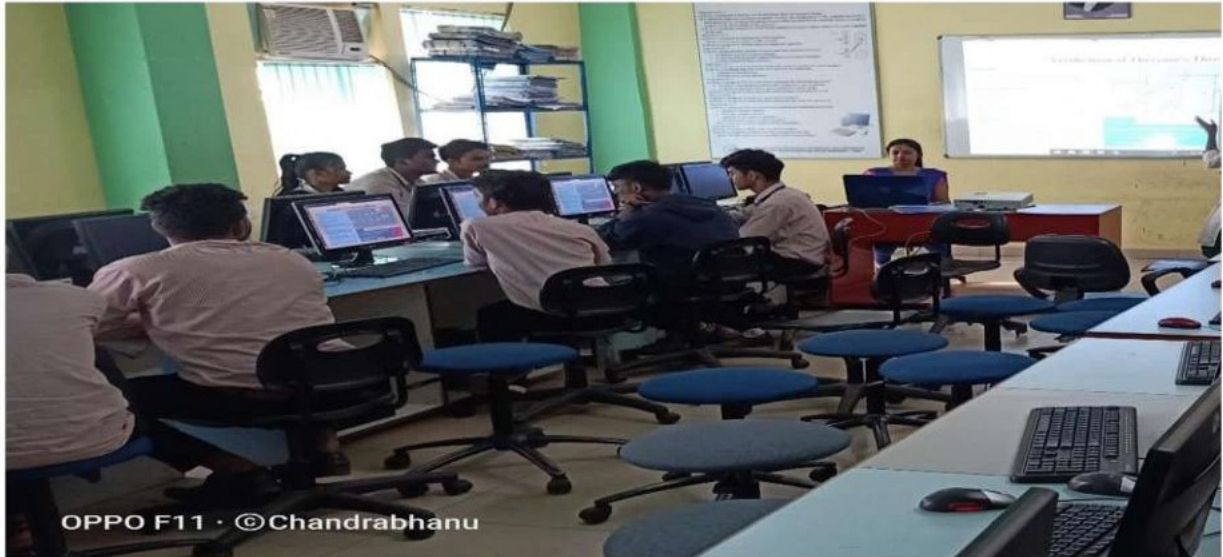

Principal
Radhakrishna Institute of Technology
and Engineering, Bhubaneswar



RADHAKRISHNA INSTITUTE OF TECHNOLOGY AND ENGINEERING

REPORT ON ONE DAY SEMINAR ON

WORKSHOP- SUPPORT REACTION

Background:

- A support can refer to a variety of structures in architecture that includes arches, beams, columns, balconies and stretchers.
- Generally the support reactions are of two types i.e positive support reaction and negative support reaction.
- This seminar is organized to understand that the types of support reaction, usages of support reaction and manufacturing of the support reaction etc.

Date and Venue:

- The seminar took place on 12th september 2017 at the Seminar Hall of RITE, Bhubaneswar. The training program is organized by RITE.
- The subject of the workshop was "SUPPORT REACTION".

Training Team:

- Mr.Pradeep Kumar Mahapatra(keynote speaker) and faculties of civil engineering department of RITE explained about support reaction, types of support reaction, application of support reaction etc.

Agenda:

Time	Events
02.30	Welcoming to RITE.
02.45	Lightening the lamp.
03.00	Welcoming to RITE management to the dais.
03.10	Welcome address by Director.
03.15	Guest Speech.
03.30	Training program.
04.30	Vote of thanks by HOD , Civil Engineering Department.

Principal
Radhakrishna Institute of Technology
and Engineering, Bhubaneswar

Participants:

- Total 70 nos of participants including 3rd sem, 5th sem and 7th sem Civil Engineering students, Mr. S.S. Kanungo (A.D.), Mr. Captain N.C. Sarma (Advisor), Mr. P.C.Das (Dean-Academics) and faculties of civil engineering department of RITE participated in the seminar.



Outcomes of the Seminar:

- Students are able to understand basic need of support reaction.
- Manufacturing of support reaction.
- Types of support reaction.
- Application of support reaction.
- Good workmanship practice.

Seminar Photographs:



Principal
Radhakrishna Institute of Technology
and Engineering, Bhubaneswar

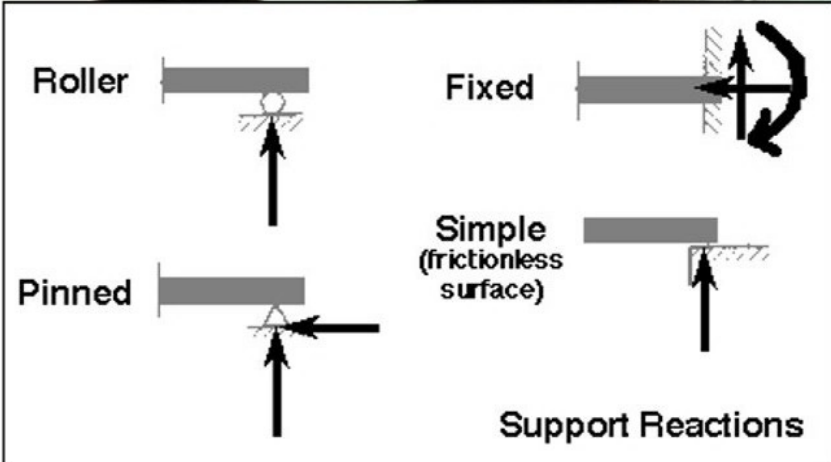

Civil engineering students of 3rd semester, 5th semester, 7th semester, Proff. Samyukta Choudhury (HOD), faculties of civil engineering department at the main entrance to welcome ACC LTD delegates Mr. Pradeep kumar Mahapatra (keynote speaker).

Principal
 Radhakrishna Institute of Technology
 and Engineering, Bhubaneswar



Ms Prajna Parimita (Assistant Professor-Civil Engineering Department) welcomes to 3rd sem, 5th sem, 7th sem Civil Engineering students, Mr. S.S. Kanungo (A.D.), Mr. Captain N.C. Sarma (Advisor), Mr. P.C.Das (Dean-Academics), Shri Sachidananda Nayak (Odisha Head-Technical), Mr. Ratan Mishra (Manager-Technical), faculties of all departments of RITE and addressing to the delegates of ACC LTD & management of RITE to the dias.

Principal
Radhakrishna Institute of Technology
and Engineering, Bhubaneswar



Miss Prajna Parimita (Assistant Professor-Civil Engineering Department) addressing Mr. Sasanka Sekhar Kanungo (A.D.), Mr. Captain Naveen Chandra Sarma (Advisor), Mr. P.C.Das (Dean-Academics), Shri Sachidananda Nayak (Odisha Head-Technical) and Mr. Ratan Mishra (Manager-Technical) to light the



Mr. Sasanka Sekhar Kanungo (A.D) speaking about modern construction techniques, application of support reaction and the prime accountability of future civil engineers.

Mr. Pradeep Kumar Mahapatra(keynote speaker) is explaining about "Support reaction"

Principal
Radhakrishna Institute of Technology
and Engineering, Bhubaneswar



Shri Santosh Kumar Swain, Assistant Professor-Civil Engineering Department is explaining about "Support Reaction".

Principal
Radhakrishna Institute of Technology
and Engineering, Bhubaneswar

THANK YOU



"Live as if you were to die tomorrow, Learn as if you were to live forever." — [Mahatma Gandhi](#)



Principal
Radhakrishna Institute of Technology
and Engineering, Bhubaneswar

**REPORT ON ONEDAY WORKSHOP PROGRAMME ON****“STREET LIGHT AUTOMATION IN SMART CITY”****Background:**

- ✚ Electronics engineering, is an electrical engineering discipline which utilizes nonlinear and active electrical components (such as semiconductor devices, diodes and integrated circuits) to design electronic circuits, devices, microprocessors, micro controllers and other systems. The discipline typically also designs passive electrical components, usually based on printed circuit boards.
- ✚ Electronics is a subfield within the wider electrical engineering academic subject but denotes a broad engineering field that covers subfields such as analog electronics, digital electronics, embedded systems and power electronics.
- ✚ The first question is what is meant by a ‘smart city’. The answer is, there is no universally accepted definition of a smart city. It means different things to different people. The conceptualisation of Smart City, therefore, varies from city to city and country to country, depending on the level of development, willingness to change and reform, resources and aspirations of the city residents.
- ✚ A smart city is an urban development vision to integrate information and communication technology in a secure fashion to manage a city's assets. These assets include local departments' information systems, schools, libraries, transportation systems, hospitals, power plants, water supply networks, waste management, law enforcement, and other community services.
- ✚ Information and communication technology (ICT) is used to enhance quality, performance and interactivity of urban services, to reduce costs and resource consumption and to improve contact between citizens and government.
- ✚ Street lighting is a core piece of urban and rural infrastructure. Lighting helps to create a safe environment for both pedestrians and drivers. Streetlights have long been a major cost for local government. Although they offer immediate benefits in terms of street safety, the cost of running thousands of streetlights for many hours of the day adds up.
- ✚ New technologies allow these costs to be reduced or controlled. By replacing traditional sodium lamps with energy efficient LED lamps, running costs can be cut by up to 60%, as well as providing a brighter street environment. These new bulbs also last much longer than traditional bulbs, reducing maintenance costs significantly.



- ✚ Generally, street lights are switched on for whole night and during the day, they are switched off. But during the night time, street lights are not necessary if there is no traffic. Saving of this energy is very important factor these days as energy resources are getting reduced day by day.
- ✚ Automatic Street Light Control System is a simple and powerful concept, which uses transistor as a switch to switch ON and OFF the street light automatically. By using this system manual works are removed.
- ✚ It automatically switches ON lights when the sunlight goes below the visible region of our eyes. It automatically switches OFF lights under illumination by sunlight. This is done by a sensor called Light Dependant Resistor (LDR) which senses the light actually like our eyes.
- ✚ Automatic Streetlight needs no manual operation of switching ON and OFF. The system itself detects whether there is need for light or not. When darkness rises to a certain value then automatically streetlight is switched ON and when there is other source of light, the street light gets OFF.
- ✚ The purpose of doing smart city project is to create awareness among students, and create an opportunity to put their creativity to work in making their environment better.

Date and Venue:

- The workshop took place on 13th September 2017 at the Seminar Hall of RITE, Bhubaneswar. The training program was organized by RITE in association with M/S: Dreams Project, Bhubaneswar.
- The subject of the workshop was “Street Light Automation in Smart City”.

Training Team:

- The resource person was Mr. Soumya Ranjan Nayak (MD, Dreams Project, Bhubaneswar) explained about the role of street light in smart city.

Principal
Radhakrishna Institute of Technology
and Engineering, Bhubaneswar

**Agenda:**

Time	Events
Session 1	
10.30 am	Welcoming to Dreams Project delegates to RITE.
11.00 am	Offering Bouquet to delegates.
11.05 am	Welcoming to Dreams Project delegates and RITE management to the dais.
11.10 am	Welcome address by HOD, Electronics & communication engineering Department.
11.15 am	Guest Speech
11.30 am	Training program
01.00pm	Lunch Break
Session 2	
1.45pm	Practical Session
4.00pm	Vote of thanks by Asst. Prof. Sanjiv Kumar Pal, Electronics & communication engineering Department.

Participants:

- Total 30 numbers of participants (7th, 5th, 3rd & 1st Semester) of Electronics & Communication Engineering, and Electrical Engineering, Mr. P.C.Das (Dean-Academics) and faculties of Electronics & communication engineering department of RITE participated in the workshop.

Principal
Radhakrishna Institute of Technology
and Engineering, Bhubaneswar

WORKSHOP PHOTOGRAPHS



Mr. Sangram Sahoo, HOD (Electronics & communication engineering Department) welcomes to participants (7th, 5th, 3rd & 1st Semester) of Electronics & Communication Engineering, Electrical Engineering, Mr.P.C.Das (Dean-Academics) and faculties of Electronics & communication engineering and addressing to the delegates of Dreams Project of RITE to the Dias.



Mr.Soumya Ranjan Nayak (MD, Dreams Project) explaining about the role of Street Light in Smart City.

Principal
 Radhakrishna Institute of Technology
 and Engineering, Bhubaneswar



Doubt clearing session in workshop.



Students are experimenting with the equipments required for street light automation.

Principal
Radhakrishna Institute of Technology
and Engineering, Bhubaneswar



Vote of thanks given by Asst.Prof Sanjiv Kumar Pal, Electronics & communication engineering Department.

Prepared By;
Asst.Prof.Rasmita Lenka
ECE Department.



Principal
Radhakrishna Institute of Technology
and Engineering, Bhubaneswar

WORKSHOP REPORT

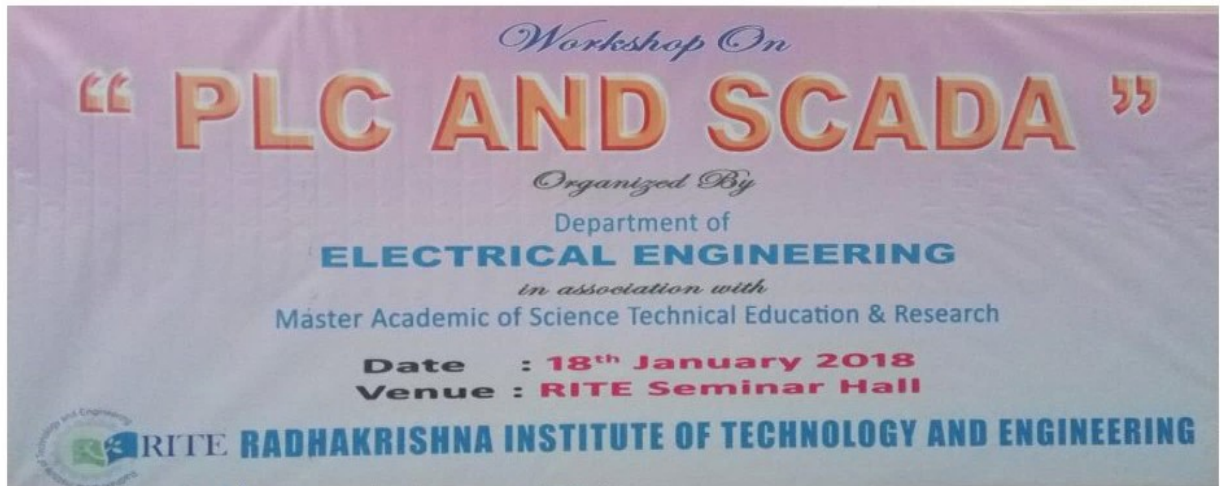

Organized by

Department of Electrical Engineering

RITE, BHUBANESWAR, 18th Jan 2018



Principal (RITE)
Radhakrishna Institute of Technology
and Engineering, Bhubaneswar
IDCO Plot No. 1, Khurda Industrial Estate, Barunei, Bhubaneswar - 752097

Objective:

- To understand the generic architecture and constituent components of a Programmable Logic Controller.
- To develop architecture of SCADA explaining each unit in detail.
- To develop a software program using modern engineering tools and technique for PLC and SCADA.
- To apply knowledge gained about PLCs and SCADA systems to identify few real-life industrial applications

Resource persons:

- Master Academy of science technical education and research which is a renowned training institute for industrial automation in Bhubaneswar.
- Bijayananda Biswal, Managing Director MASTER
- Amit Kumar Satpathy, Director Academic, MASTER

Workshop Co-Ordinators-

Prof Subash Ranjan Kabat, HOD Department of EE

Prof Deepak Kumar Sahoo , Asst Prof ,Department of EE

Prof Surya Narayan Tripathy, Asst Prof ,Department of EE

Prof Chinmayee Mishra, Asst Prof ,Department of EE

Prof Barsha Parija ,Asst Prof ,Department of EE

Prof Priyadarshinee Das, Asst Prof ,Department of EE



Principal
Radhakrishna Institute of Technology
and Engineering, Bhubaneswar

Agenda:

- 11.00am- Welcome of Guests by the Hod of Electrical Engg
- 11.05am- Overview of the workshop objectives by B N Biswal
- 11.30am- Presentation
- 1.00pm- Lunch
- 2.00pm-Hands on: Automation Machineries
- 3.30pm-Summary and workshop Adjourn
- 4.00pm-Vote of Thanks By Prof Chinmayee Mishra

Topics covered:

The Programmable Logical Controller (PLC) was invented in response to the needs of the American automotive industry. Before the PLC, control, sequencing, and safety interlock logic for manufacturing automobiles was accomplished using relays, timers and dedicated closed-loop controllers. The process for updating such facilities for the yearly model change-over was very time consuming and expensive, as the relay systems needed to be rewired by skilled electricians.

A SCADA (supervisory control and data acquisition) is an automation control system that is used in industries such as energy, oil and gas, water, power, and many more. The system has a centralized system that monitors and controls entire sites, ranging from an industrial plant to a complex of plants across the country. A SCADA system works by operating with signals that communicate via channels to provide the user with remote controls of any equipment in a given system.

AUTOMATION:

AUTOMATION is basically the delegation of human control functions to technical equipment aimed towards achieving: Higher productivity. Superior quality of end product. Efficient usage of energy and raw materials. Improved safety in working conditions etc.

TYPES OF AUTOMATION-

Principal
Radhakrishna Institute of Technology
and Engineering, Bhubaneswar

Building automation Example: lifts, smoke detectors.

Scientific automation Example: rocket launching

Industrial automation Example: automated bottle filling stations, steel factories etc

PLC SCAN CYCLE & SCAN TIME

While the PLC is running, the scanning process includes the four phases, which are repeated continuously as individual cycles of operation:

- Input Scan- Scan the state of the Inputs
- Program Execution- Processes and executes the program logic
- Housekeeping- This step includes communications, Internal Diagnostics, etc.
- Output Scan- Energize/deenergize the output.

Participants: UG students, EE and ECE Department

Number of Participants: 39

Outcome of Event:

The event was very helpful to the UG students to learn and to have hands on PLC and SCADA technology. They learned how to atomize the system using PLC programing and to design the same in SCADA.

Student shared their expertise by doing small project using the software, they were also happy to take up their project in PLC and SCADA and implement new ideas on automation

EVENT PHOTOGRAPHS:



Principal
Radhakrishna Institute of Technology
and Engineering, Bhubaneswar



[Handwritten signature]

Principal
Radhakrishna Institute of Technology
and Engineering, Bhubaneswar



Handwritten signature in green ink.

Principal
Radhakrishna Institute of Technology
and Engineering, Bhubaneswar



A handwritten signature in green ink, likely belonging to the Principal of Radhakrishna Institute of Technology and Engineering.

Principal
Radhakrishna Institute of Technology
and Engineering, Bhubaneswar



Principal
Radhakrishna Institute of Technology
and Engineering, Bhubaneswar



Report Prepared By:

Prof Subash Ranjan Kabat(Hod,EE)

Prof Deepak Kumar Sahoo(Asst Prof ,EE)

Principal
Radhakrishna Institute of Technology
and Engineering, Bhubaneswar

2018

FUTURE TECHNOLOGY IN INDUSTRIES & INTERNET OF THINGS”



Submitted By:
Principal
Radbhakshna Institute of Technology
and Engineering, Bhubaneswar
10/2/2018

**REPORT ON ONE DAY SEMINAR ON
“FUTURE TECHNOLOGY IN INDUSTRIES & INTERNET OF THINGS”**

10th February 2018

Background:

- ✦ Industrial production is nowadays driven by global competition and the need for fast adaptation of production to the ever-changing market requests. These requirements can be met only by radical advances in current manufacturing technology.
- ✦ Industry 4.0 is a promising approach based on integration of the business and manufacturing processes, as well as integration of all actors in the company’s value chain (suppliers and customers).
- ✦ Technical aspects of these requirements are addressed by the application of the generic concepts of Cyber-Physical Systems (CPS) and industrial Internet of Things (IoT) to the industrial production systems.
- ✦ The Industry 4.0 ‘execution system’ is therefore based on the connections of CPS building blocks. These blocks are embedded systems with decentralized control and advanced connectivity that are collecting and exchanging real-time information with the goal of identifying, locating, tracking, monitoring and optimizing the production processes.
- ✦ Furthermore, an extensive software support based on decentralized and adapted versions of Manufacturing Execution Systems (MES) and Enterprise Resource Planning (ERP) is needed for a seamless integration of manufacturing and business processes.
- ✦ The third important aspect is handling of a big amount of data collected from the processes, machines and products. Typically the data is stored in cloud storage. This data requires extensive analytics that lead from the ‘raw’ data to the useful information and, finally to the concrete actions that support an adaptive and continuously self-optimizing industrial production process.
- ✦ Due to the importance of this transition for the position of a country in a global market, some government-led initiatives were introduced all-around the world to support the transition. Industry 4.0, as the first such initiative and inspiration for other initiatives, comes from Germany.

Principal
Radhakrishna Institute of Technology
and Engineering, Bhubaneswar

Date and Venue:

- ✚ The seminar took place on 10th February 2018 at Conference Hall of CTTC, Bhubaneswar. The training program is organized by Central Tool room and Training Centre (CTTC), Bhubaneswar
- ✚ The subject of the seminar was “**FUTURE TECHNOLOGY IN INDUSTRIES & INTERNET OF THINGS**”.

Contents:

Industry 4.0

3D Printing

Internet of Things

Training Team:

- The resource persons are **Mr. Sibasis Maity**, Managing Director, CTTC, Bhubaneswar, **Mr. L. Rajasekhar**, Dy. General Manager, CTTC, Bhubaneswar, **Ms. Nidisha Maganti**, Operation Manager, The Big IoT Platform-International, **Mr. Priya D. Shubhakanta & Mr. Manoranjan Sahoo**, 3D Printing Experts, CTTC, Bhubaneswar.

Agenda:

Timing	Programmes
9:30 A.M- 10:00 A.M.	Registration
10:00 A.M- 10:15 A.M.	Welcome Address by Mr. Sibasis Maity , Managing Director, CTTC, Bhubaneswar
10:15 A.M- 10:45 A.M.	Brief Introduction about CTTC by Mr. L. Rajasekhar , Dy. General Manager, CTTC, Bhubaneswar
10:45 A.M- 11:00 A.M.	Tea Break
11:00 A.M- 12:15 P.M.	Technical Session (Fourth Industrial Revolution & Industry 4.0) by Mr. Sibasis Maity
12:15 P.M- 01:15 P.M.	Technical Session (Internet of Things) by Ms. Nidisha Maganti , Operation Manager, The Big IoT Platform-International
01:15 P.M-02:00 P.M.	Lunch Break
02:00 P.M-03:00 P.M	CTTC Tour
03:00 P.M- 4:00 P.M.	Technical Session (Rapid Prototyping & 3D Printing) by Mr. Priya D. Shubhakanta & Mr. Manoranjan Sahoo , 3D Printing Experts, CTTC, Bhubaneswar
04:00 P.M.- 04:15 P.M.	Vote of Thanks by Mr. K.M. Rajan, Sr. Manager (Training), CTTC, Bhubaneswar
04:15 P.M.- 04:30 P.M.	Validation & T.A Claim

Principal
Radhakrishna Institute of Technology
and Engineering, Bhubaneswar

Participants:

- Total 103 numbers of participants from Different Engineering Colleges and Industries of Odisha. From RITE, Bhubaneswar the participants for the Seminar are:

Sl. No.	Name of the Faculty	Designation
1	Prof. Chandrabhanu Malla	Asst. Prof. & H.O.D., Dept. of Mechanical Engg.
2	Prof. Samyukta Choudhury	Asst. Prof. & H. O. D., Dept. of Civil Engg.
3	Prof. Subash Ranan Kabat	Asst. Prof. & H.O.D., Dept. of Electrical Engg.
4	Prof. Amitav Saran	Asst. Prof., Dept. of Computer Science & Engg.

Scheme of Industrial Revolution and 4th Generation Industry:

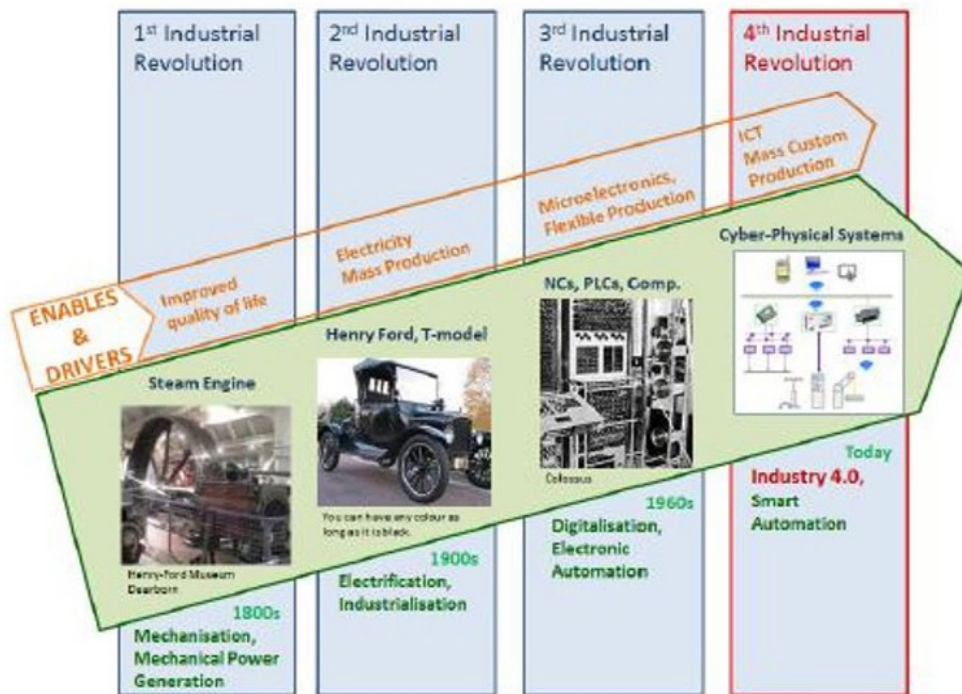

(Through the Industrial Revolution)

Outcomes of the Seminar:

- The participants can able to explain the concept of Industry 4.0
- Application of Internet of Things (IoT) in the Modern Manufacturing system
- Necessity and uses of Cloud Computing.
- Application of Artificial Intelligence (AI)
- Concept of Rapid Prototyping
- Application and Importance of 3D printing over Conventional Manufacturing Process.

Principal
Radhakrishna Institute of Technology
and Engineering, Bhubaneswar

SEMINAR PHOTOGRAPHS



Registration of Participants at Registration Desk



Welcome Address by the members of Organising Committee
Principal
Radhakrishna Institute of Technology
and Engineering, Bhubaneswar



Brief Introduction about CTTC, Bhubaneswar by Mr. L. Rajasekhar, Dy. General Manager, CTTC, Bhubaneswar



Technical Session (Internet of Things) by **Ms. Nidisha Maganti**, Operation Manager, The Big IoT Platform-International

Principal
Radhakrishna Institute of Technology
and Engineering, Bhubaneswar



Technical Session (Fourth Industrial Revolution & Industry 4.0) by Mr. Sibasis Maity



CTTC Tour

Principal
Radhakrishna Institute of Technology
and Engineering, Bhubaneswar



Technical Session (Rapid Prototyping & 3D Printing) by **Mr. Priya D. Shubhakanta & Mr. Manoranjan Sahoo**, 3D Printing Experts, CTTC, Bhubaneswar



Vote of Thanks by Mr. K.M. Rajan, Sr. Manager (Training), CTTC, Bhubaneswar
Principal
Radhakrishna Institute of Technology
and Engineering, Bhubaneswar

THANK YOU



Principal
Radhakrishna Institute of Technology
and Engineering, Bhubaneswar

Department of Electrical Engineering

Report On

“Grid Operation and Role of SLDC”

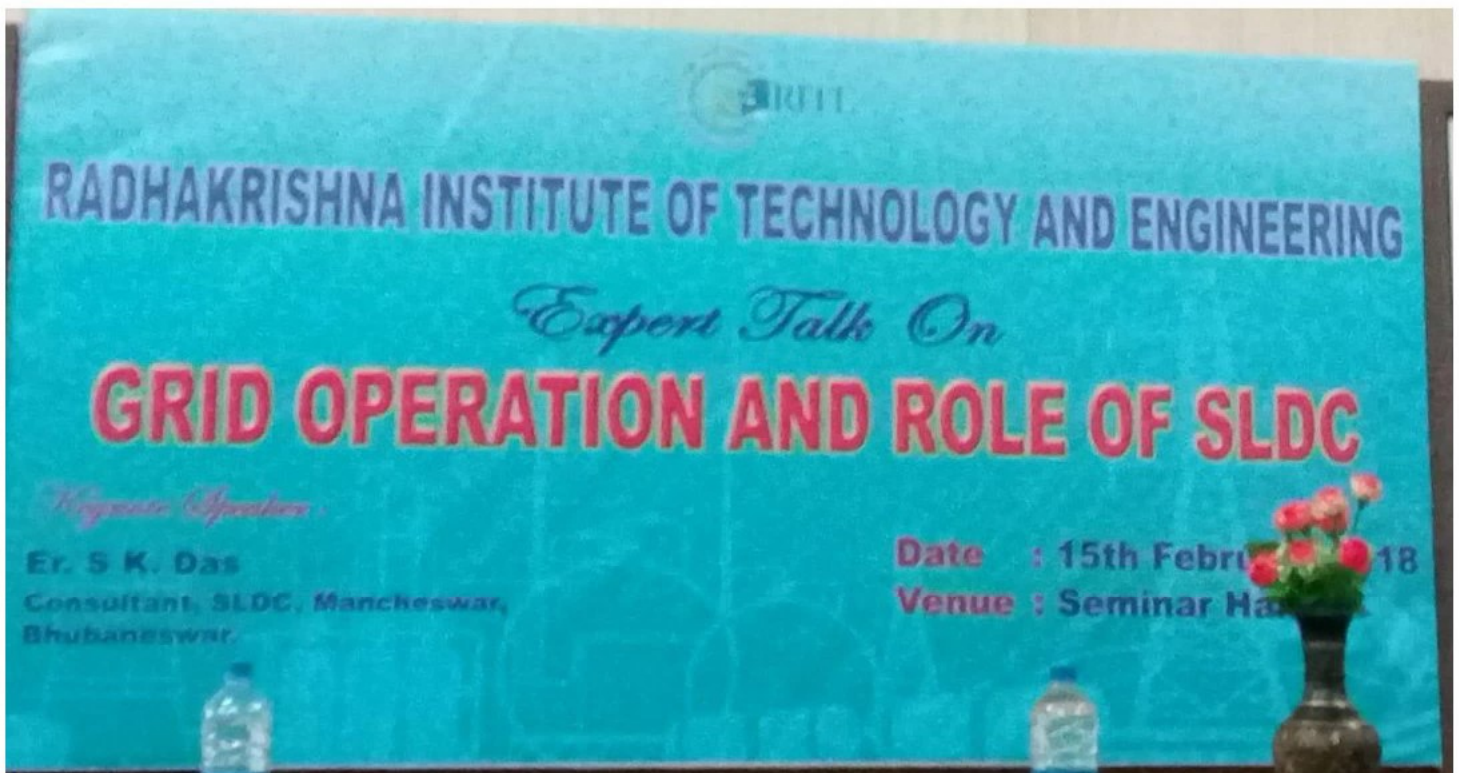

**EXPERT: Mr. Santosh Kumar Das
Consultant Head
SLDC, BHUBANESWAR**



Principal

**Radhakrishna Institute of Technology
and Engineering (RITE)**

RADHAKRISHNA INSTITUTE OF TECHNOLOGY AND ENGINEERING (RITE)
IDCO Plot No. 1, Khurda Industrial Estate, Barunei, Bhubaneswar – 752057

Date and Time: 15th FEBRUARY-2018, 02.00pm

Venue: RITE seminar hall

Duration: 3 hours

Faculty Co-ordinators:

Prof. Subash Ranjan Kabat (Head, EE Department)

Prof. Deepak Kumar Sahoo (Asst Professor, EE Department)

Prof. Barsha Parija (Asst Professor, EE Department)

Prof. Chinmayee Mishra (Asst Professor, EE Department)

Prof. Surya Narayan Tripathy (Asst Professor, EE Department)

Total Number of Students: 39

Expert Profile:

Mr. Santosh Kumar Das

Address: Mancheswar

Bhubaneswar

Work Profile: Retired from OPTCL as General Manager.

He worked with Grid Operation since 1998.

He worked in different locations of OSEB.

Now he is working of main consultant in SLDC.

Website: www.slhc.co.in



Principal
Radhakrishna Institute of Technology
and Engineering, Bhubaneswar

TRAINING TEAM

The members of the training team of “**Grid Operation and Role of SLDC**” organized by the faculty members of Electrical Engineering department, RITE, Bhubaneswar.

AGENDA

<u>TIME</u>	<u>EVENTS</u>
2.00PM	Inauguration
2.05 PM	Welcoming the Guests to the dais
2.10 PM	Welcome speech by Hod,EE
2.15 PM	Welcome Address by Director
2.30PM	Talk By S K Das,CONSULTANT,SLDC
4.45 PM	Vote of Thanks by Prof B Parija

ABOUT EXPERT TALK:

Students gathered around 1:30 pm on 15th February, Thursday for Expert Lecture. Talk initiated at 02:15am with an auspicious prayer. Dignitaries were welcomed to the dias.

A Welcome speech was given by Prof. S R Kabat(Hod ,EE). A brief speech motivating students to pursue careers in innovative tech industry was given by Prof. S P Mishra (Director, RITE). The Director also introduces the expert to the gatherings. After that the Expert Mr. S K Das started his talk about “**Grid Operation Nad Role of SLDC**”.

TECHNICAL SUMMARY:

- Mr. Das presented that an electrical grid is an interconnected network for delivering electricity from producers to consumers.
- It consists of generating stations that produce electrical power, high voltage transmission lines that carry power from distant sources to demand centers, and distribution lines that connect individual customers.
- The electricity grid is a complex and incredibly important system, and one of the most impressive engineering feats of the modern era.

GRID MANAGEMENT:

to operate the transmission system by

- issuing operating instructions to the field engineers through grid operator
- ensure moment-to-moment power balance in the control area
- Monitoring the power flow through the inter connected transmission line.

Principal
Radhakrishna Institute of Technology
and Engineering, Bhubaneswar

AID FOR GRID MANAGEMENT

- To enhance the power system visibility and improve the quality of supervision of grid operation on real time basis, the control rooms at the national, regional and state level have been equipped with a state-of-the-art communication and data acquisition system.
- The vital system variables are measured by RTUs / transducers installed at all the important locations. The recorded data is transmitted through communication channels and ultimately displayed in the operator consoles in the load dispatch centers.
- Communication System acts like the sensory organs of the grid operators and helps them to diagnose the system condition and to take corrective measures.

FUNCTIONS OF SLDC

Section 32 (2), EA 2003:

The State Load Despatch Centre shall -

- (a) be responsible for optimum scheduling and dispatch of electricity within a State, in accordance with the contracts entered into with the licensees or the generating companies operating in that State;
- (b) Monitor grid operations;
- (c) Keep accounts of the quantity of electricity transmitted through the State grid;
- (d) Exercise supervision and control over the intra-state transmission system.
- (e) be responsible for carrying out real time operations for grid control and dispatch of electricity within the State through secure and economic operation of the State grid in accordance with the Grid Standards and the State Grid Code

AVAILABILITY BASE TARIFF

Availability Base Tariff is a self disciplinary mechanism applicable to the generators as well as buyers / beneficiaries to maintain the committed generation or drawal through schedule. Aim of ABT is to maintain the system frequency within the standard Operating band as decided by the CERC.

PARTICIPANTS

All the faculty members of RadhaKrishna Institute of Technology and Engineering .Also the lovely technocrats with their uniform participate in the Expert Talk.

OUTCOMES OF THE EXPERT TALK

- ❖ Learn about the technology behind the transmission system.
- ❖ Learn about the new technology of the protection system.
- ❖ Learn about the reason behind the blackout condition of power system.
- ❖ Learn about the technical modification of transmission and protection system.



Principal
Radhakrishna Institute of Technology
and Engineering, Bhubaneswar

PHOTOGRAPHS:



(Welcome speech by Hod, EE)



(Address by Diector.RITE)



(Talk by Expert S K Das)



[Handwritten signature]
Principal
Radhakrishna Institute of Technology
and Engineering, Bhubaneswar

VALEDICTORY SESSION:

The expert talk was over at 4.45 pm. Then vote of thanks has been given by the Head of the department, Electrical engineering. After that the Director felicitated the expert. The expert talk on emerging power system was completed at 5 pm.



REPORT PREPARED BY:

Prof Subash Ranjan Kabat
HOD, EE

Principal
Radhakrishna Institute of Technology
and Engineering, Bhubaneswar



WORKSHOP ON

“Emerging Automotive Technology for Emission Control, with Ashok Leyland iEGR Technology”

[Bharat stage emission standards (BSES) are emission standards instituted by the Government of India to regulate the output of air pollutants from internal combustion engines and Spark-ignition engines equipment, including motor vehicles]

**Organized By Department of Mechanical Engineering,
RITE, BHUBANESWAR**

2/16/2018



Principal
Radhakrishna Institute of Technology
and Engineering, Bhubaneswar

Emerging Automotive Technology for Emission Control, with Ashok Leyland “iEGR” Technology

Background

Skill is the unified force of experience, intellect and passion in their operation. Skill India portal was conceptualized to provide a collaboration platform to help all the stakeholders to freely connect with each other. The overall focus of this initiative is to help provide an engaging ecosystem to cater to skilling needs of citizens by publishing and sharing relevant information. Introduced in 2000, the Bharat norms are emission control standards that are based on the European regulations (Euro norms). They set limits for release of air pollutants from equipment using internal combustion engines, including vehicles. Typically, the higher the stage, the more stringent the norms. The BS IV norms were introduced in 13 cities apart from the National Capital Region from April 2010 onwards. According to the roadmap, the entire nation was to be covered under BS IV by April 1, 2017. BS IV fuel was also to be made available across the country from April 1 this year.

BS IV norms stipulate only 50 parts per million sulphur compared with up to 350 parts per million under BS III. Also, hydrocarbon, nitrogen oxide and particulate matter emissions are lower under BS IV.

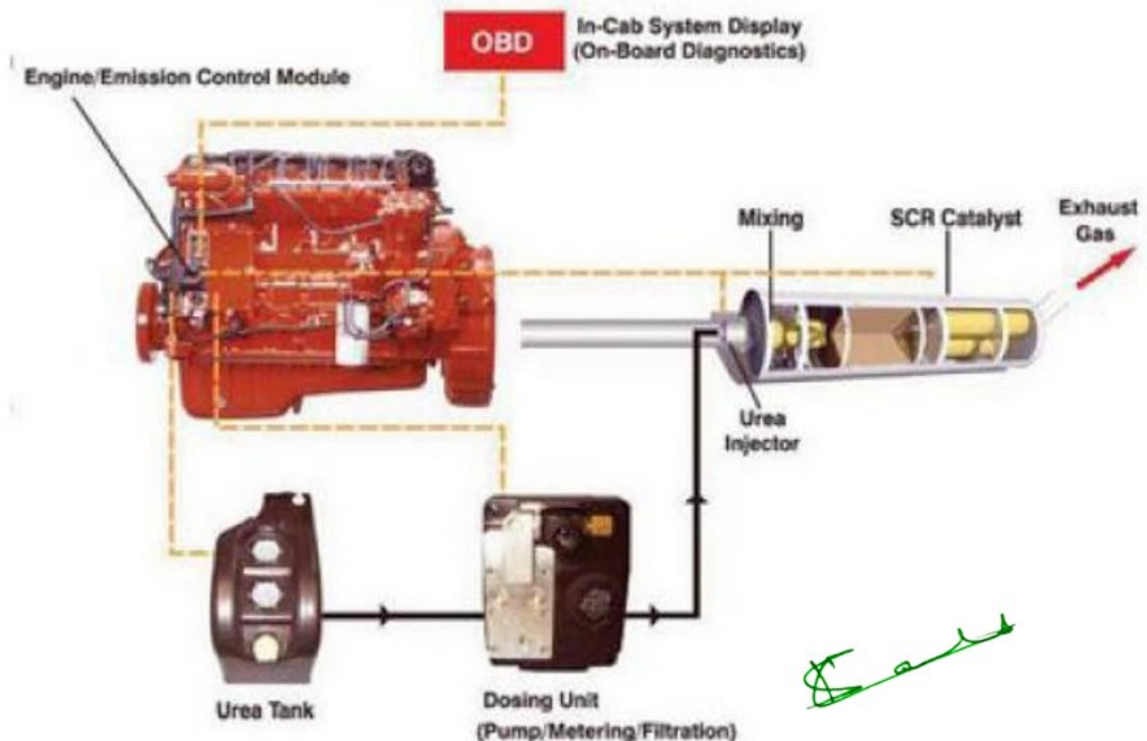

Principal
Radhakrishna Institute of Technology
and Engineering, Bhubaneswar

Date and Venue

The training-workshop held on 16th Feb. 2018 at the Seminal Hall of RITE, Bhubaneswar. The training team arrived at the venue 10:00 A.M, in order to meet for fine-tuning of the agenda and coordinate the workshop.

Training Team

The members of the training team of Mission Dream Skill India program in-association with Sky-Rider Automotive are Mr. Himansu Sekhar Panda, Programme Coordinator, Mr. Rakesh Kumar Patra, Mr. Nihar Panda and Mr. Sanjay Kumar Panda.

AGENDA

Sl. No.	Time	Events
1	10.15 AM	Inauguration
2	10:30 AM	Welcoming the Guests to the dais by Prof. M. Arya
3	11:00 AM	Guest Lecture on “iEGR” Technology
4	01:00 PM	Lunch Break
5	02:00 PM	Special Program by Ashok Leyland
6	04:30PM	Valedictory Ceremony
7	04:45PM	Vote of Thanks by Prof. C. B. Malla

Participants

The training-workshop was attended by 63 students from 2nd year, 3rd year and 4th year of Mechanical Engineering Branch.

The main motto of this workshop is to educate the students about the hidden concept of BS-IV and iEGR technology used in Vehicle.

Commercial vehicle technologies for BS IV emissions compliance

The main purpose of Emissions Regulations is to limit, reduce and control air pollution. Emission control is a function of engine technology, fuel quality and traffic speed (congestion).

Principal
Radhakrishna Institute of Technology
and Engineering, Bhubaneswar

On July 15 the MOSRTH issued the draft notification for the next stage of emissions regulations. According to draft notification GSR 522, effective April 1, 2010, Bharat Stage IV norms will be applicable to 11 metros while Bharat Stage III will be applicable to the rest of the country.

Trucks and buses are predominantly powered by heavy duty diesel engines. Modern diesel engines are lighter and are more powerful, fuel efficient and environment-friendly. Bharat Stage IV diesel engines in 2010 will have particulate matter (PM) emissions that are over 95 per cent lower than the Bharat 2000 (BS 1) diesel engines manufactured in the early part of this decade.

This emission reduction is achieved by a combination of improved diesel engine technology and low sulphur (50 ppm) diesel fuel. Combined with reduced traffic congestion this has the potential to check air pollution dramatically.

Today there are two proven approaches to Euro IV emissions compliance. High pressure common rail fuel injection forms the foundation and is common to either approach. Then, to reduce oxides of nitrogen (NO_x) and particulate matter in diesel exhaust, the first option is the selective catalytic reduction (SCR) after-treatment approach and the second is exhaust gas recirculation (EGR) with diesel oxidation catalyst or open filter.

SCR is based on running an optimized combustion in the engine that allows it to operate at more optimal combustion temperatures providing better power, fuel efficiency and lower soot (PM) generation. But this process produces higher NO_x. To reduce NO_x to levels required by emissions standard, a synthetic urea solution such as Adblue is injected into the exhaust stream. In the presence of a catalyst, Adblue turns into ammonia and carbon-dioxide, which then reacts with the NO_x to create nitrogen and water Vapour, or $2N_2 + 3H_2O$.

The SCR catalyst also acts to reduce soot to an extent. Thus the SCR process reduces soot or PM in engine combustion and NO_x and further PM reduction in the after-treatment system.

Now about cooled exhaust gas recirculation (EGR) + DOC / open filter. Cooled EGR introduces cooled exhaust gas, which is low in oxygen, back into the engine, depriving the combustion event of some of its oxygen. This reduces the combustion temperature and lowers NO_x production. The downside is that the lower-temperature diesel combustion is less efficient, so it creates more particulate matter and burns more fuel.

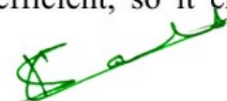

Principal
Radhakrishna Institute of Technology
and Engineering, Bhubaneswar

The high soot or particulate matter produced during combustion is reduced using oxidation catalyst or open filter. This process results in significantly increased engine heat rejection. In contrast to the SCR process, this process reduces NO_x in the engine and soot in the after-treatment process.

As with all technology comparisons aimed at proving the same solution, there are pros and cons to consider for both the technologies that enable compliance to Euro IV emissions. However, both solutions are proven technologies for markets to choose from.

The accompanying table shows a comparison of both technologies across various parameters.

Manufacturers in Europe have implemented both technologies successfully. European production numbers indicate that vehicles with SCR outnumber those with EGR + DOC/ open filter nearly two to one.

In India

Effective April 1, 2010, Bharat Stage IV norms are applicable to 11 metros while Bharat Stage III will be applicable to the rest of the regions in India. This implies that BS IV diesel, with 50 ppm sulphur, will be available in the metros, while BS III diesel, with 350 ppm sulphur, will be available in the rest of the country. As commercial vehicles ply across the country, it will be impossible to ensure that BS IV vehicles fill only BS IV fuel.

The negative impact of repeated filling with BS III diesel can be fairly significant for BS IV engines based on cooled EGR + DOC / open filter technology.

The EGR cooler and other engine components are quite vulnerable to the Sulphuric acid nuclei formed during the EGR process. Modern coatings offer a fair degree of protection against this situation. However, long-term durability using diesel with higher sulphur content is suspect.

Multiple SAE papers documented that the effectiveness of the DOC / open filter to reduce soot or particulate matter strongly depends on the soot burden and the engine operating point. Repeated fills with BS III diesel is expected to increase the soot burden significantly, raising doubts about long-term emission stability due to catalyst aging and irreversible adhesion of ash particles.

The durability of the SCR system, on the other hand, is not negatively impacted by the usage of BS III diesel. But the system needs an external reducing agent, Adblue, to function effectively.

Principal
Radhakrishna Institute of Technology
and Engineering, Bhubaneswar

Key concerns on SCR technology center around availability of Adblue in India and vehicle operator's effectiveness in refilling it on depletion.

The European and Australian experience suggests that Adblue distribution network is unlikely to be a problem. It is expected that industrial chemical distribution companies will take the lead to distribute Adblue through their channels and / or through the vehicle manufacturer channels.

The bigger issue is to ensure that the vehicle operator takes responsibility for refilling Adblue at required intervals. This can be achieved through a combination of driver warning systems, emissions monitoring system and driver inducement system.

The driver warning system (dashboard indication) informs the vehicle operator that Adblue is low and must soon be replenished. The driver inducement system acts as a back-up by triggering engine shutdown or reducing power to a "limp mode" in case a driver attempts to operate the vehicle without proper replenishment. The emission monitoring system, consisting of a NOx sensor at the tail pipe, measures actual NOx emissions. In case the operator uses diluted reducing agents or no reducing agent the sensor will detect high NOx emissions and trigger action by the driver inducement system.

Thus, in the Indian context, the choice of EGR + DOC / open filter or SCR distills down to a question of balancing two opposing risks, i.e., the risk of reduced engine durability and emissions durability on account of high sulphur / adulterated fuel usage for EGR + DOC / open filter versus operator effectiveness in refilling Adblue for the SCR system.

It is expected that the SCR system, coupled with the driver warning system, emissions monitoring system and the driver inducement system, is a lower risk from the standpoint of engine durability and pollution reduction.

In India, fuel cost is said to contribute as much as 50-60 per cent of operating costs, and SCR delivers better fuel efficiency compared to cooled EGR + DOC / open filter. This tips the balance in favor of SCR as the preferred solution in the Indian context, especially when viewed through the lens of lower risk on engine durability, and emissions durability and better fuel economy.

Outcomes of the Training-Workshop

After the completion of this workshop, the students are able to analyse the following things.

- ✓ Understood the complete parts of BS-4 engine.

Principal
Radhakrishna Institute of Technology
and Engineering, Bhubaneswar

- ✓ Understood the composition of the Fuel at engine inlet and at the exhaust.
- ✓ Participants came to know about the Emission effect and composition of the harmful gases coming out of Combustion chamber from the engine.
- ✓ The Participants came to know how AL believes its BS4 solution based on iEGR technology (v/s SCR technology adopted by competitors) gives it significant competitive advantage with potential to gain market share. iEGR not only results in lower cost by INR40-42k/unit than SCR, but also offers ~10% higher mileage than BS3, lower maintenance cost, and better payload.
- ✓ Understood the Concept of NO_x and how it can be reduced by using “iEGR” technology.
- ✓ Understood the concept of why and how the “iEGR” technology is employed in Reduction and recirculation of Exhaust gas.
- ✓ Practically the Students understood the parts of Ashok Leyland engine and how the “iEGR” technology is applied to the engine as well as they learned about the detection of troubleshooting of any component in engine by manual and using tool kit.



Principal
Radhakrishna Institute of Technology
and Engineering, Bhubaneswar

WORKSHOP MEMORIES



(Hoisting the workshop By Prof. Mamuni Arya)



(Presentation of flower Bouquet to the Delegates of Sky Rider Automotive)

Principal
Radhakrishna Institute of Technology
and Engineering, Bhubaneswar



(Welcoming the delegates to the dais)



(Introductory speech by Mr. Rakesh Kumar Patra, Sky-Rider Automotive)

Principal
Radhakrishna Institute of Technology
and Engineering, Bhubaneswar



(Over View of MTTR and Sky-Rider Automotive By Mr. Himansu Sekhar Panda)



(Technical Session on BS-IV and iEGR technology By Mr. Nihar Ranan Panda, Ashok Leyland)

Principal
Radhakrishna Institute of Technology
and Engineering, Bhubaneswar

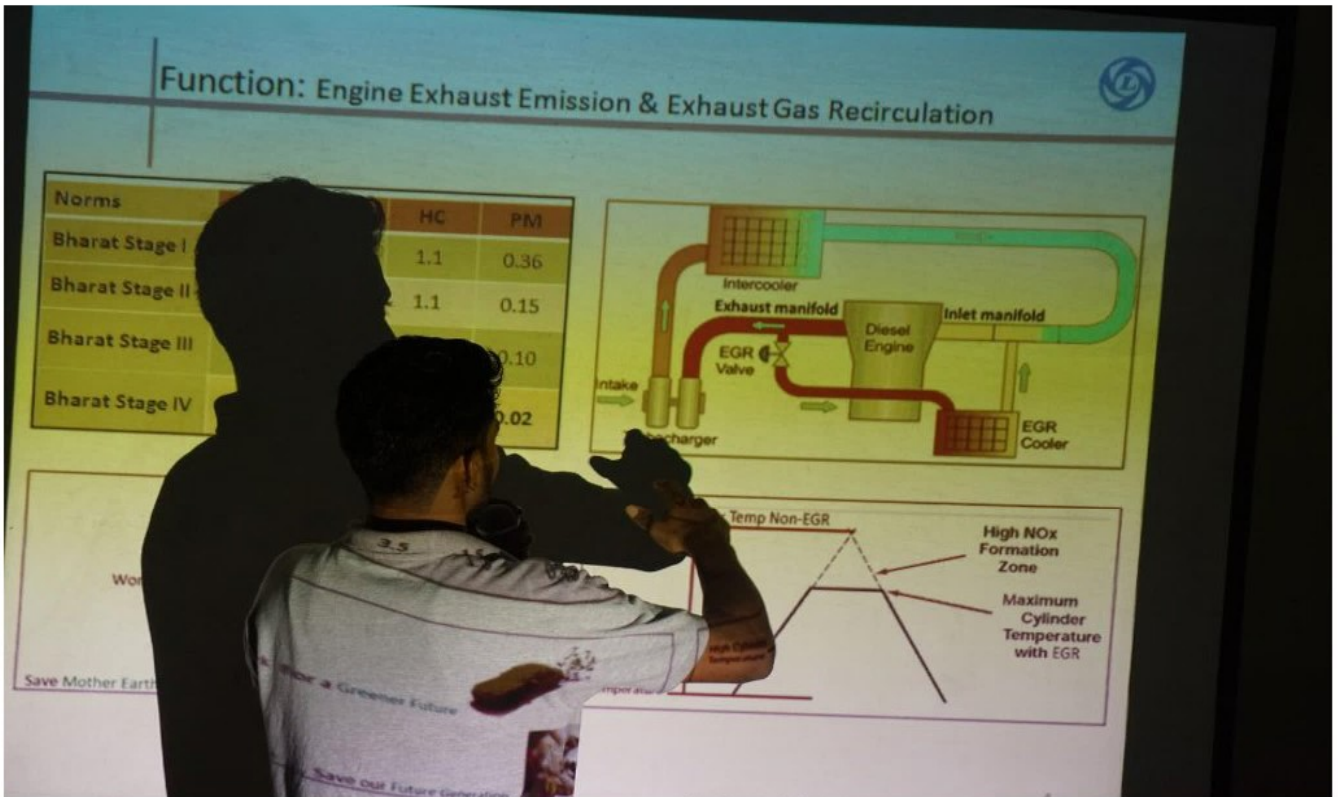

(Technical session on the functioning of BS-IV engine by Mr. Nihar Ranjan Panda, Ashok Leyland)



(Interaction of Mr. Nihar Ranjan Panda with Mechanical student)

Principal
Radhakrishna Institute of Technology
 and Engineering, Bhubaneswar



(Snap showing participants of the workshop)



(Declaration of End of Pre-Lunch session by Prof. Chandrabhanu Malla, H.O.D., Mechanical)

Principal
Radhakrishna Institute of Technology
and Engineering, Bhubaneswar



(Training Session on Ashok Leyland KNOW Vehicle)



(Ashok Leyland KNOW Vehicle)

[Handwritten Signature]

Principal
Radhakrishna Institute of Technology
and Engineering, Bhubaneswar

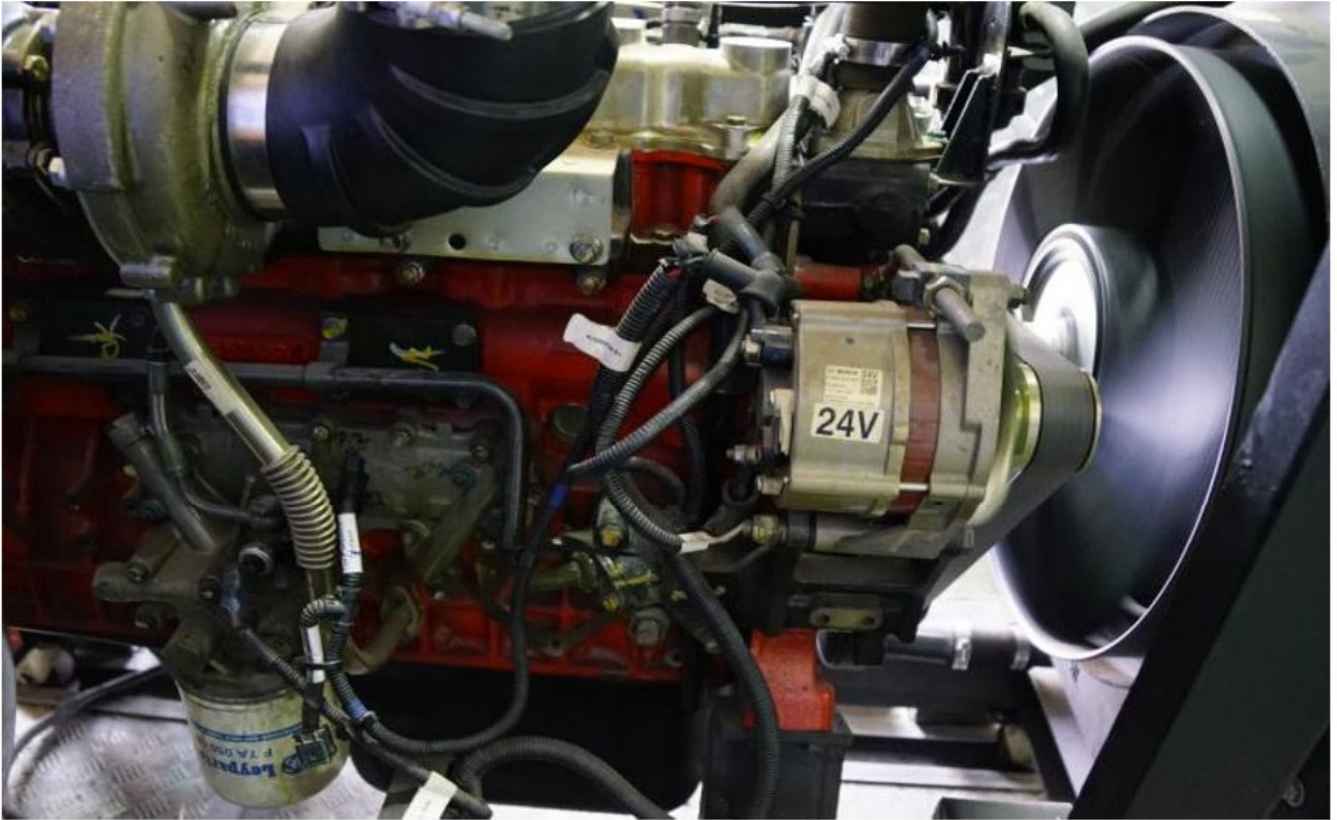

(View of Ashok Leyland BS-IV Engine)



(Prof.(Dr.) S.S. Kanungo, Asst. Director with Faculty members, on the Tutorial Section of KNOW Vehicle)

Principal
Radhakrishna Institute of Technology
and Engineering, Bhubaneswar



(Prof.(Dr.) S.S. Kanungo, Asst. Director with Faculty members, listening about the functioning of BS-IV Engine)



(Prof.(Dr.) S.P. Mishra, Director, Prof. P.C. Das, Dean (Academics) with Faculty members, on the Tutorial Section of KNOW Vehicle)

Principal
Radhakrishna Institute of Technology
and Engineering, Bhubaneswar



(Vote of thanks by Prof. Chandrabhanu Malla, H.O.D., Mechanical)



(Delegates of Sky Rider automotive with Dean (Academics) and faculty member of Department of Mechanical Engineering)

Principal
Radhakrishna Institute of Technology
and Engineering, Bhubaneswar



[Handwritten signature]

Principal
Radhakrishna Institute of Technology
and Engineering, Bhubaneswar

THANK YOU



Principal
Radhakrishna Institute of Technology
and Engineering, Bhubaneswar

GLIDER DESIGN

**SURYA NARAYAN
BEHERA**

2018



**Department Of Mechanical Engineering
RITE, BHUBANESWAR**

**Principal
Radhakrishna Institute of Technology
and Engineering, Bhubaneswar**

“REPORT ON GLIDER DESIGN”



Submitted By:
Prof. Surya Narayan Behera
22/2/2018

Principal
Radhakrishna Institute of Technology
and Engineering, Bhubaneswar



REPORT ON “GLIDER DESIGN”

22TH February 2018

Background:

- A Glider is a heavier than air craft that is supported in flight by the dynamic reaction of the air against its lifting surfaces, and whose free flight does not depend on an engine.
- Most gliders do not have an engine, although motor gliders have small engines for extending their flight when necessary with some being powerful enough to take off.
- Glider design is based on principle of aero dynamics.
- Gliders are principally used for the air sport gliding, hang gliding and paragliding.

Date and Venue: The technical event took place on 22th February 2018 at central laboratory RITE. The technical activity was organized by Department of Mechanical Engineering.

AGENDA:

Timing	Programmes
1.00pm-1.15pm	Registration
1.15pm-1.30pm	Welcome Address & small technical advice by Prof. Chandrabhanu Malla ,
1.30pm-1.45pm	Material collection by the students from Mechanical Workshop
1.145pm-3.15pm	Design & Fabrication of Glider
3.15pm -4.30pm	Technical Presentation & Flying of Glider
4.30pm-4.35pm	Closing Ceremony

Principal
Radhakrishna Institute of Technology
and Engineering, Bhubaneswar

Participants:

Total six number of groups participated in the event & each group consist of five to six number of students from second year, third year & fourth year of mechanical branch:

Sl. No.	Name	Designation
1	Prof. (Dr.) S. P. Mishra	DIRECTOR
2	Prof. (Dr.) S. S. Kanungo	ASST DIRECTOR
3	Prof. P. C. Das	DEAN (ACADEMICS)
4	Prof. (Dr.) Shivani Rath	DEAN (SAW)
5	Mr. A. K. Nayak	DEAN (ADMIN.)
5	Prof. Chandrabhanu Malla	HOD Dept. Of Mechanical Engg
6	Prof. Prafulla Sahu	Asst Prof. Dept. Of Mechanical Engg
7	Prof. Susanta Kumar Sahu	Asst Prof. Dept. Of Mechanical Engg
8	Prof. Mamuni Arya	Asst Prof. Dept. Of Mechanical Engg
9	Prof. Amit Jain Biswal	Asst Prof. Dept. Of Mechanical Engg
10	Prof. Surya Narayan Behera	Asst Prof. Dept. Of Mechanical Engg

The Glider was flying by the students, distance of flight & time of flight were recorded by taking three observations.



Principal
Radhakrishna Institute of Technology
and Engineering, Bhubaneswar
(Design and Fabrication of Glider of participants)



(Observation by Director RITE during Glider Fabrication)



Principal
Radhakrishna Institute of Technology
(Observation by Prof. Amit Jain Biswal (Mechanical Engg) during Glider Fabrication)



(Observation by Prof. Chandrabhanu Malla (HOD, Mechanical Engg) during Glider Fabrication)



(Observation by Prof. Mamuni Arya (Asst. Prof., ME) during Glider Fabrication)



(Observation by Prof. Chandrabhanu Malla, Prof. Prafulla Kumar Sahoo, Prof. Surya Narayan Behera (Mechanical Engg. Department) during Glider Fabrication)



(Photo shoots by the students after the completion of Glider with the organizing team member)



(Photo shoots by the participants with the Academic and Administrative team member)



(Snap showing Glider in air)

THANK YOU



Principal
Radhakrishna Institute of Technology
and Engineering, Bhubaneswar

Report On
Entrepreneurship Awareness Camp
13th March, 2018
Held at Radhakrishna Institute of Technology &Engineering,
Bhubaneswar.

Organized By
Rainmaker Group



**RADHAKRISHNA INSTITUTE OF TECHNOLOGY AND
ENGINEERING, BHUBANESWAR- 752057 (ODISHA)**

A handwritten signature in green ink, appearing to be "S. S. S.", is written over a horizontal line.

Principal
Radhakrishna Institute of Technology
and Engineering, Bhubaneswar

BACKGROUND

Great thinkers and visionaries all over the world have repeatedly predicted India and China as the future drivers of the global economy. At the heart of this economic transition is the entrepreneurial action. In today's' knowledge economy Indians are leaving their entrepreneurial footprints all over the world.

The National Knowledge Commission in its' report has strongly emphasized the role of education in catalyzing Entrepreneurship, especially in the highly skilled and knowledge-driven sectors. Though entrepreneurship is not new to India, however, entrepreneurship as a subject in Technical/Technology institutions and entrepreneurship as a career option is gaining momentum only recently as the emergence of knowledge based techno-pruners all over the world. Though entrepreneurship forms an important subject in Science & Technology studies, whether in polytechnic or engineering, it does not form a substantial part of the curriculum. As most science and technology institutions would like to see their students as entrepreneurs and would also like to be a part of the entrepreneurship development process mainstream. Like any other field, entrepreneurship as a subject studies and entrepreneurship as a practice are two different things.

Time and again question that is raised on to-How is it that the students of Science & Technology seldom take the entrepreneurship and while studies offer knowledge, there is very little opportunity to learning the process of becoming entrepreneurs. Since the objective of the entire studies is for facing the examination, there is hardly any effort in developing the skill and motivation of entrepreneurship within the curriculum.

With a view to create awareness among faculty and students of Engineering courses about various facets of entrepreneurship as an alternative career option an 'Entrepreneurship Awareness Camp' is conducted at Radhakrishna Institute of Technology & Engineering ,Bhubaneswar, Odisha

This programe was organized by Rainmaker Group, Bhubaneswar, Odisha



Principal
Radhakrishna Institute of Technology
and Engineering, Bhubaneswar

Date and Venue

The entrepreneurship awareness camp took place on 13th March 2018 at the Seminal Hall of RITE, Bhubaneswar. A bunch of 64 students of RITE took part in the training program. The training team arrived at the venue 1-30 PM, in order to meet for fine-tuning of the agenda and coordinate the workshop.

Training Team

The entrepreneurship awareness camp was organized by Rainmaker Group. Mr. Saroj Kumar Nanda Programme Director, Dr. Kailash Chandra Nayak (Director, Seehurd) and Mr. Arun Kumar Parija motivated the participants to achieve and excel in life whether in job- employment or in self-employment.

Agenda

Time	EVENTS
2.10pm	Inauguration
2.20pm	Welcoming the Guests to the dais
2.30pm	Training Session
4.30pm	Vote of Thanks by Prof. C.B.Malla

REPORT ON THE AWARENESS CAMP

Considering the objectives of the entrepreneurship awareness programme and the expectations of the participants, the programme contents, delivery and sequence was fine-tuned on the very first day of the programme. During the entire programme participative learning methods like, group work, simulation exercises, role play, case discussions etc was extensively used in addition to informative lectures with audio-visual presentations. The participants were encouraged to challenge the concepts, ask questions and participate actively in the class-room interactions. The class room learning was supplemented by well compiled course material and handouts.

The programme was conducted at Radhakrishna Institute of Technology & Engineering, Bhubaneswar for 1 day.

Followings are the brief summary of the programme conducted.



Principal
Radhakrishna Institute of Technology
and Engineering, Bhubaneswar

The programme Director Mr. Saroj Kumar Nanda then briefed the participants about the structure, design of the programme and spelt out the expectations of the organizers from the participants. The session was devoted to an interactive session on “Introduction to Entrepreneurship and Charms of becoming an entrepreneur”. The session started with a question for the students to think over what is it that they would like to gain out of their life ultimately. This session enabled the students to understand their aspirations, inclinations and passions and then shape up their career option accordingly. Entrepreneurship was presented in a broader sense as a way of thinking and acting leading to wealth creation in a chosen career path. Finally a difference was made between the traditional entrepreneurs and the knowledge entrepreneurs/technology entrepreneurs.

Second session was devoted to Entrepreneur competencies & Risks Vs Rewards and was handled by Dr. Kailash Chandra Nayak (Director, Seehurd). He introduced the students to entrepreneurial motivations, values and attributes with help of different exercises. Some examples of business, corporate and social entrepreneurs like Mr. Dhirubhai Ambani, Mr. Charles etc were presented so as to make them aware about the entrepreneurial manifestations in different fields. The participants were also taken through the way the term “Entrepreneurship’ is evolving over the years.

The third session of the programme started with a motivation session on “Business Idea Generation and Creativity” by Mr. Arun Kumar Parija. He explained the students the process of creating value proposition, evolving a business model and delivering the value to the customers by using innovative ideas.

The last session of the programme, Mr. S.P. Mishra (Director, RITE) and Mr. P.C.Das (Dean Academic, RITE) emphasized the need for entrepreneurship and highlighted how the entrepreneurial eco-system has changed in recent times. He urged the students to take maximum advantage of the growing economy by venturing in to their own business.

Outcomes of the entrepreneurship awareness camp

- After the completion of this entrepreneurship awareness camp, the students learned a lot about Entrepreneurship. The program was very informative and enlightening.
- Provided exposure to the Entrepreneurship.
- It was full of Ideas.

Principal
Radhakrishna Institute of Technology
and Engineering, Bhubaneswar

- Got to know about venture capitalist and investors.
- Because it has provided general idea of entrepreneurship.
- Provide awareness about the entrepreneurship.
- Full knowledge about entrepreneur support system was given.
- Taught Entrepreneurship as a whole and its related systems.



Principal
Radhakrishna Institute of Technology
and Engineering, Bhubaneswar

Report
on

“Entrepreneurship Awareness Camp”

Held on: 13TH March 2018

Program Venue: RITE, Bhubaneswar

Organized

by

Rainmaker Group

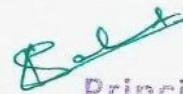

Principal
Radhakrishna Institute of Technology
and Engineering, Bhubaneswar

BACKGROUND

Great thinkers and visionaries all over the world have repeatedly predicted India and China as the future drivers of the global economy. At the heart of this economic transition is the entrepreneurial action. In today's knowledge economy Indians are leaving their entrepreneurial footprints all over the world.

The National Knowledge Commission in its report has strongly emphasized the role of education in catalyzing Entrepreneurship, especially in the highly skilled and knowledge-driven sectors. Though entrepreneurship is not new to India, however, entrepreneurship as a subject in Technical/Technology institutions and entrepreneurship as a career option is gaining momentum only recently as the emergence of knowledge based techno-pruners all over the world. Though entrepreneurship forms an important subject in Science & Technology studies, whether in polytechnic or engineering, it does not form a substantial part of the curriculum. As most science and technology institutions would like to see their students as entrepreneurs and would also like to be a part of the entrepreneurship development process mainstream. Like any other field, entrepreneurship as a subject studies and entrepreneurship as a practice are two different things.

Time and again question that is raised on to-How is it that the students of Science & Technology seldom take the entrepreneurship and while studies offer knowledge, there is very little opportunity to learning the process of becoming entrepreneurs. Since the objective of the entire studies is for facing the examination, there is hardly any effort in developing the skill and motivation of entrepreneurship within the curriculum.

With a view to create awareness among faculty and students of Engineering courses about various facets of entrepreneurship as an alternative career option an 'Entrepreneurship Awareness Camp' is conducted at Radhakrishna Institute of Technology & Engineering, Bhubaneswar, Odisha

This program was organized by Rainmaker Group, Bhubaneswar, Odisha

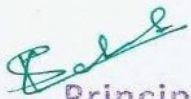
Principal
Radhakrishna Institute of Technology
and Engineering, Bhubaneswar

Date and Venue

The entrepreneurship awareness camp took place on 13th March 2018 at the Seminal Hall of RITE, Bhubaneswar. A bunch of 64 students of RITE took part in the training program. The training team arrived at the venue 1-30 PM, in order to meet for fine-tuning of the agenda and coordinate the workshop.

Training Team

The entrepreneurship awareness camp was organized by Rainmaker Group. Mr. Saroj Kumar Nanda Programme Director, Dr. Kailash Chandra Nayak (Director, Seehurd) and Mr. Arun Kumar Parija motivated the participants to achieve and excel in life whether in job-employment or in self-employment.

Agenda

Time	Events
2.10 PM	Inauguration
2.20 PM	Welcoming the Guests to the dais
2.30 PM	Training Session
4.30 PM	Vote of Thanks by Prof. C.B.Malla

Principal
Radhakrishna Institute of Technology
and Engineering, Bhubaneswar

DETAILS ON THE AWARENESS CAMP

Considering the objectives of the entrepreneurship awareness programme and the expectations of the participants, the programme contents, delivery and sequence was fine-tuned on the very first day of the programme. During the entire programme participative learning methods like, group work, simulation exercises, role play, case discussions etc was extensively used in addition to informative lectures with audio-visual presentations. The participants were encouraged to challenge the concepts, ask questions and participate actively in the class-room interactions. The class room learning was supplemented by well compiled course material and handouts.

The programme was conducted at Radhakrishna Institute of Technology & Engineering, Bhubaneswar for 1 day.

Followings are the brief summary of the programme conducted.

The programme Director Mr. Saroj Kumar Nanda then briefed the participants about the structure, design of the programme and spelt out the expectations of the organizers from the participants. The session was devoted to an interactive session on "Introduction to Entrepreneurship and Charms of becoming an entrepreneur". The session started with a question for the students to think over what is it that they would like to gain out of their life ultimately. This session enabled the students to understand their aspirations, inclinations and passions and then shape up their career option accordingly. Entrepreneurship was presented in a broader sense as a way of thinking and acting leading to wealth creation in a chosen career path. Finally a difference was made between the traditional entrepreneurs and the knowledge entrepreneurs/technology entrepreneurs.

Second session was devoted to Entrepreneur competencies & Risks Vs Rewards and was handled by Dr. Kailash Chandra Nayak (Director, Seehurd). He introduced the students to entrepreneurial motivations, values and attributes with help of different exercises. Some examples of business, corporate and social entrepreneurs like Mr. Dhirubhai Ambani, Mr. Charles etc were presented so as to make them aware about the entrepreneurial manifestations in different fields. The participants were also taken through the way the term "Entrepreneurship" is evolving over the years.

The third session of the programme started with a motivation session on "Business Idea Generation and Creativity" by Mr. Arun Kumar Parija. He explained the students the process of creating value proposition, evolving a business model and delivering the value to the customers by using innovative ideas.

Principal
Radhakrishna Institute of Technology
and Engineering, Bhubaneswar

The last session of the programme, Mr. S.P. Mishra (Director, RITE) and Mr. P.C.Das (Dean Academic, RITE) emphasized the need for entrepreneurship and highlighted how the entrepreneurial eco-system has changed in recent times. He urged the students to take maximum advantage of the growing economy by venturing in to their own business.

Outcomes of the Entrepreneurship Awareness Camp

- After the completion of this entrepreneurship awareness camp, the students learned a lot about Entrepreneurship. The program was very informative and enlightening.
- Provided exposure to the Entrepreneurship.
- It was full of Ideas.
- Got to know about venture capitalist and investors.
- Because it has provided general idea of entrepreneurship.
- Provide awareness about the entrepreneurship.
- Full knowledge about entrepreneur support system was given.
- Taught Entrepreneurship as a whole and its related systems.

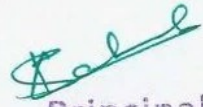
Principal
Radhakrishna Institute of Technology
and Engineering, Bhubaneswar

PHOTOGRAPHS



K. S. S.
Principal
Radhakrishna Institute of Technology
and Engineering, Bhubaneswar

**Report
On**
“Awareness program on E-Waste Management”

Held on 22 March 2018

Organized by
NSS Unit in association with IQAC, RITE, Odisha



Principal
Radhakrishna Institute of Technology
and Engineering, Bhubaneswar

Background:

Electronic waste or **e-waste** describes discarded electrical or electronic devices. It is also commonly known as waste electrical and electronic equipment (WEEE) or end-of-life (EOL) electronics. Used electronics which are destined for refurbishment, reuse, resale, salvage recycling through material recovery, or disposal are also considered e-waste. Informal processing of e-waste in developing countries can lead to adverse human health effects and environmental pollution. The growing consumption of electronic goods due to the digital revolution and innovations in science and technology, such as bitcoin, has led to a global e-waste problem and hazard. The rapid exponential increase of e-waste is due to frequent new model releases and unnecessary purchases of electrical and electronic equipment (EEE), short innovation cycles and low recycling rates, and a drop in the average life span of computers. Electronic scrap components, such as CPUs, contain potentially harmful materials such as lead, cadmium, beryllium, or brominated flame retardants. Recycling and disposal of e-waste may involve significant risk to the health of workers and their communities.

Name of the Speaker: Dr. S.R. Mishra



Principal
Radhakrishna Institute of Technology
and Engineering, Bhubaneswar

Brochure of the event:

RADHAKRISHNA INSTITUTE OF TECHNOLOGY AND ENGINEERING



e-WASTE MANAGEMENT

On 22nd / Mar/ 2018

Venue : Seminar Hall

100%
recycling
of all e-waste

Recycle | Refine | Refurbish



Principal
Radhakrishna Institute of Technology
and Engineering, Bhubaneswar

Objective

To raise awareness among the students of RITE about E-waste Management and its significance.

Schedule of the Event

Time	Event
12.00pm-12.10pm	Inaugural ceremony
12.10 pm-12.20pm	Introductory speech by Prof. Mamuni Arya
12.20pm-01.20pm	Talk delivered on “E-Waste Management” by the expert.
1.20 pm-1.30pm	Vote of thanks & felicitation by honorable Principal, RITE.



Principal
Radhakrishna Institute of Technology
and Engineering, Bhubaneswar

Notice:

Radhakrishna Institute of Technology &
Engineering, Bhubaneswar
(BPUT affiliated, AICTE approved & NAAC accredited)



REF. NO. RITE/2017-18/574(A) DATE: 20.03.2018

NOTICE

Sub: - "Awareness Programme on E-Waste Management"

This is for the information of all students and staff that "RITE Young Tarang" in association with IQAC-RITE is going to organize an "Awareness Programme on E-waste Management" on 22nd March 2018. All students are hereby advised to complete the registration process for the aforesaid programme by visiting the college website on or before 21st March 2018.

Details of Programme:

Event Name: Awareness Programme on E-Waste Management

Date : 22.03.2018

Time : 02:00 PM

Venue : Seminar Hall

DIRECTOR

Copy to: Advisor/Asst. Director/ All Deans/ NBs

Principal
Radhakrishna Institute of Technology
and Engineering, Bhubaneswar

RITE Bhubaneswar, IDCO Plot-1, IDCO Industrial Estate, Barunei, Bhubaneswar-752057, India
Tefax: 91-6755-220242, Email: riteodisha@gmail.com Web: www.riteindia.in

Principal
Radhakrishna Institute of Technology
and Engineering, Bhubaneswar

List of Participants

Sl. No	Name
1	Pritimayee Panda
2	Seema Mahalik
3	Namrata Apat
4	Payal Priyadarshini
5	Madhusmita Sahoo
6	Arati Mishra
7	Anisha Priyadarshini
8	Ipsita Singh
9	Vinnangee Pradhan
10	Ankita Das
11	Kamine
12	Rahul Baroi
13	Debasish Mahanta
14	Rahul Das
15	Jagabandhu Karan
16	Sujit Mohapatra
17	Madhusmita Behera
18	Abinash Nayak
19	Ranjita Rana
20	Trupti Priyadarshini
21	ChinamManas
22	Niharika Das
23	Sagarika Mishra
24	Laxmipriya Das
25	Deepak Ku. Sahoo

Sl. No	Name
26	Soumya Ranjan Patra
27	Sritam Dash
28	Sonali Ojha
29	Somesh panda
30	Sunita S. Sethy
31	Nityaranjan Kabasi
32	Manisha Priyadarshini
33	Pitambara Majhi
34	Sakuntala Behera
35	Abinash Routray
36	Santosh Mishra
37	Lali Naik
38	Nabin Munda
39	Rashmiprava Biswal
40	Priyanka Khosla
41	Nitesh Kumar Tudu
42	Amit Kumar Majhee
43	Biswajit Dhal
44	Sudhir Das
45	Biswajit Sahoo
46	Animesh Panda
47	Biswajita Pattanayak
48	Jhantu Mandal
49	Zaful Khan
50	Preety Kumari



Principal
Radhakrishna Institute of Technology
and Engineering, Bhubaneswar

Photos of the Event



S. S. S.

Principal
Radhakrishna Institute of Technology
and Engineering, Bhubaneswar